



USE AND MAINTENANCE (TRANSLATION OF THE ORIGINAL INSTRUCTIONS)





SAFETY	4
GENERAL INFORMATION	10
USE SET MENU.....	16
USE MIND.MAPS MENU	26
USE PROGRAMS MENU	30
USE ROTOR.KLEAN MENU.....	34
MENU SETTINGS.....	38
ALARMS AND WARNINGS.....	44
MAINTENANCE.....	46
SUPPORT	50

CONTACTS

Please see the back cover for contacts in your local area.



Dear Customer,

This manual contains all the information you need to use and maintain this appliance correctly.

If you do not fully understand any of the contents, please contact the manufacturer for further information.

Safety

Pictograms	4
Safety information	5

PICTOGRAMS



Read the instruction manual



Danger! Situation presenting immediate danger, or a hazardous situation which could cause injury or death.



Risk of fire!



Risk of electric shock!



Risk of burns



Danger: corrosive substances.



Tips and useful information



Consult another section



Earthing symbol



Equipotential symbol

SAFETY INFORMATION



General precautions

- Failure to comply with the safety regulations, and any use or maintenance other than those indicated in this manual voids the warranty* and relieves the manufacturer of all liability.
- Keep this appliance out of the reach of children.
- Cleaning and maintenance must be done by the user and NOT by children, especially where not supervised by an adult.
- This appliance can only be used for cooking food in industrial and professional kitchens by qualified personnel, who have completed regular training courses. Any other use is not compliant with the scope of use and is therefore hazardous.
- If the appliance is not working or if you notice any changes to the structure or operation, disconnect the electricity supply and contact an authorised UNOX customer assistance service. Do not attempt to repair the appliance yourself. For any repairs, please request UNOX original spare parts.
- Failure to observe these regulations may cause damage, injury or death, and also invalidates the warranty.
- To ensure that the appliance is in perfect condition in terms of use and safety, maintenance and inspections should be performed at least yearly by an authorised support service centre.
- The appliance emits a sound level of below 70 dB.
- The humidity sensing system must be calibrated when the oven is first installed (contact the UNOX Service Centre), and as and when the oven requires it.



If the BAKERTOP MIND.Maps™ oven cannot be permanently connected to a drainage system, the terminal must be sealed with the conical plug supplied in the starter kit. When the terminal is blocked, DO NOT use the wash programs or wash the cavity with large quantities of water. Risk of flooding.



Risk of burns and injury!

- While cooking and until all appliance parts have cooled, make sure to only touch the appliance control components or handle, because the external parts are extremely hot (temperature above 60°C/140°F).
- Cooking can only take place with the door closed, for safety reasons. If the door is opened, the oven stops temporarily and a message appears on the display. To resume cooking, simply close the door again.

- In order to maintain optimum performance, do NOT open the door during cooking. If it is not possible to avoid opening the door, please do so very slowly and carefully, paying attention to the hot steam coming out of the oven cavity.
- Wear appropriate protective thermal clothing and take great care when moving containers, accessories and other objects inside the oven cavity.
- Be extremely careful when removing trays from the oven cavity.
- Extract the core probe from the food before removing the trays from the oven, and place it in the external probe holder. Before removing the tray, check that the probe cable is not in the way. Handle the probe with care because it is extremely sharp and, after use, can be very hot.
- NEVER put any type of tray, hot or cold container, or other objects on top of the oven, even if it is turned off. DO NOT put highly flammable or heat-sensitive objects (e.g. plastic ornaments, lighters, etc.) near the appliance.
- Leave at least 10 cm of free space around the oven.
- The first time you use the appliance, some of the oils used for manufacturing may evaporate and produce fumes or unpleasant odours. These will gradually disappear as you continue to use the appliance.
- Liquids or other foods should not be reheated in sealed containers, as these may explode.
- To avoid burns, do not use containers filled with liquids or products that liquefy, heating up to higher levels than can be easily observed (IEC 60335-2-42:2002 / AMD1:2008)
- If reheating beverages, these may reach boiling point and cause a delayed eruption. Be careful when handling the container.
- The contents of any baby bottles and any baby food in jars must be mixed or shaken before consumption. Check the temperature to avoid scalding.
- Only use utensils and containers that are appropriate for high temperatures.
- Do not remove or touch the protective fan casing, the fans or the heating elements while the appliance is turned on and until it has completed cooled down.
- Carefully read the product safety data sheet before handling and using the detergent.
- Do not open the oven door during a washing cycle as this could cause injury to eyes, mucous membranes and skin caused by contact with the cleaning chemicals used. These chemicals are sprayed by the rotor in the cavity and moved by strong air currents.
- When carrying out maintenance on the oven water circuit, you must use PPE specific for the detergent (see the product safety data sheet). Specifically, gloves and goggles must be used since there could be detergent residue in parts of the circuit that could be pressurised.
- Do not tamper with the oven water circuit in any circumstances because this could cause damage, injury or death. The oven water circuit begins with a 3/4" connector, with a non-return valve built in, and includes all the subsequent piping and accessories.

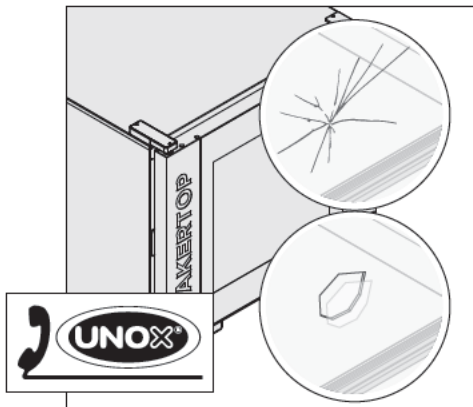

If the appliance glass is chipped or damaged, it must be replaced immediately. Please contact an authorised support service centre. Do not use the oven. Risk of exploding glass.

ONLY FOR FREE-STANDING TROLLEY OVENS:

- Always lock the front wheel brakes after loading the oven cavity and at all times when they do not need to be moved.
- Always lock the trays into their guides.
- Be extremely careful when moving the trolley because the trays may contain hot fluids that may spill or the trolleys may fall over (for example if moved across uneven floors or through doors).

 **Risk of fire**

- Before using the appliance, make sure that there are no non-compliant objects (instruction manuals, plastic bags, etc.) or detergent residues inside the oven cavity. Also make sure that the flue is free of obstructions and that there are no flammable materials in the vicinity.
- When reheating food in plastic or paper containers, check the oven. Risk of fire.
- If you notice any smoke coming from the appliance, disconnect the appliance from the mains power supply and keep the door closed to extinguish any flames.
- Do not place sources of heat (e.g. grills, fryers, etc.), highly flammable substances or fuels (e.g. diesel, petrol, bottles of alcohol, etc.) near the appliance.
- The appliance must be cleaned daily, removing any food residue. Follow the detailed cleaning instructions on page 46. Failure to carry out cleaning as indicated could cause the surfaces to deteriorate. This could reduce the life of the appliance and cause danger (if not removed, fats or food residue on the inside could catch fire).
- Do not clean the appliance with a steam or pressurised water jet.
- Do not use highly flammable food or liquids while cooking (e.g. alcohol).





Risk of electric shock!

- Do not open the compartments marked with these symbols. Only qualified personnel authorised by UNOX may access these compartments. Failure to observe this regulation invalidates the warranty* and may cause damage or injury including death.
- Any routine maintenance must be performed:
 - after disconnecting the appliance from the power supply and waiting for the capacitive components to discharge (approx. a few minutes);
 - after waiting for the appliance to cool down fully;
 - only if you are in good mental and physical condition, and are wearing suitable personal protective equipment (e.g. heat-resistant rubber gloves, eye protection, dust mask (optional), etc.).

General information

Suggestions and warnings	10
Trolley loading and use (only free-standing trolley ovens)	11
USB	12
Using the core probe	12
LCD control panel HOME screen	13
How to set values	14

SUGGESTIONS AND WARNINGS

-  **Before using the appliance, read section “Safety regulations for use” carefully**
-  **If cooking large amounts of greasy foods, place an empty tray without holes on the lowest grill rack in the oven. Alternatively, use an appropriately sized container.**

- When using the appliance for the first time, be sure to clean the inside of the oven cavity and the accessories thoroughly (see the **Maintenance** section on page 46); let the oven run empty at maximum temperature for 1 hour to eliminate any unpleasant odours created by the protective grease used in the factory.
- When the oven door is opened, heating and fan operation stops automatically. The built-in fan brake is activated (the fan continues to rotate for a short time only).
- If the appliance is left running for more than 15 minutes without an operating or automatic cleaning mode being selected, stand-by is automatically activated to save energy.
- To exit STAND-BY mode, tap the START/STOP button.
- Use the appliance at room temperature between +5°C and +35°C.
- Do not salt food inside the oven cavity. If this is not possible, clean the oven as soon as possible (see the **Maintenance** chapter on page 46).
- Beware of touching the external and internal parts of the oven during cooking and until it has completely cooled (it could reach temperatures above 60°C).
- To prevent boiling, when using containers filled with liquids or foods that liquefy with heat, only use quantities that can easily be kept under control.
-  For safety reasons, the last tray should NEVER be placed above 160 cm. If necessary to do so, **you must apply the sticker contained in the starter kit at a height of 160 cm.**
- It is always better to preheat the oven in order to compensate for the heat lost when opening the door.
- If you prefer manual preheating, we recommend setting the temperature to at least 30°C higher than the temperature required for cooking.

- In order to maintain optimum performance, **do NOT open the door during cooking**. If it is not possible to avoid opening the door, please do so very slowly and carefully, paying attention to the hot steam coming out of the oven cavity.
- Use the UNOX grills and trays; try to distribute food uniformly on these while avoiding stacking and excessive quantities. Always respect the loading instructions for your appliance.
- Do not use highly flammable food or liquids while cooking (e.g. alcohol or wine).

Blackout

If there is a machine black-out or shut down, when the appliance restarts, the program that was running previously is resumed. The duration of the cooking cycle may be extended by a maximum of 2 minutes.

When navigating and setting parameters only use your finger (which must be clean and dry); avoid using tools such as forks, spoons, etc. The pen provided must only be used for drawing the cooking curves on the Mind.Maps menu and for signatures.

TROLLEY LOADING AND USE

(only free-standing trolley ovens)

- ⊕ Use only UNOX trolleys, trays and grills. Load the trolleys without overloading them: it is normal for them to drop, depending on how full the trays are. The trolley is loaded into the oven using the bottom trolley guides. Lock the trays into place when moving the trolley as shown in the figure. Always lock the front wheel brakes after loading the oven cavity and at all times when they do not need to be moved.

Be extremely careful when moving the trolley because the trays may contain hot fluids that may spill or the trolley itself may tip over (for example if moved across uneven floors or through doors).

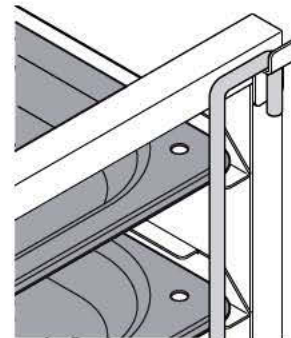
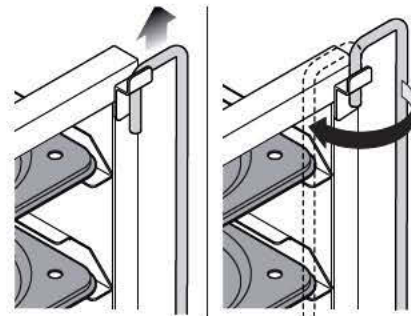

01

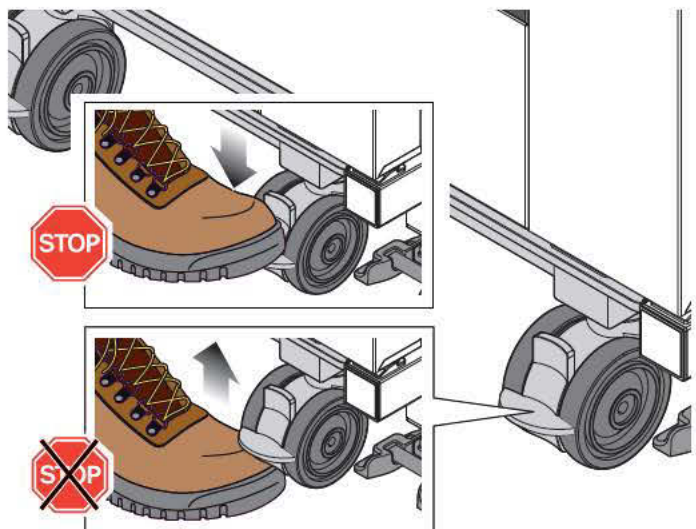

02

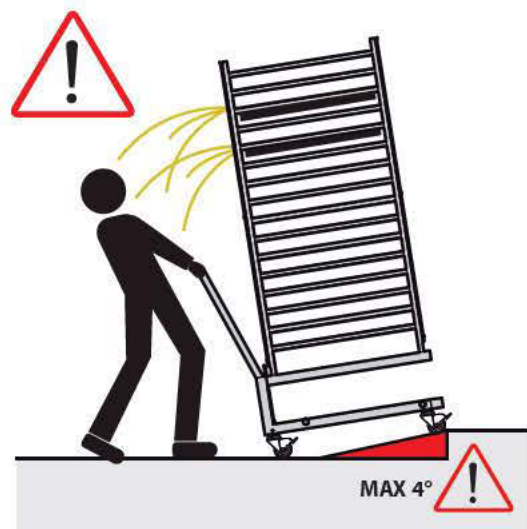

03

USB

04 ▶ The USB port is located below the LCD panel and allows you to import or export materials from your own USB stick (FT32 formatted and with capacity between 4 and 16 GB).

For information on managing the USB stick, please see ▶ p. 41.

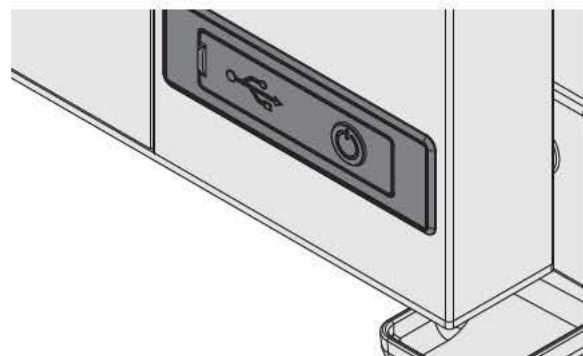

USING THE CORE PROBE

05 ▶ During the cooking cycle, the probe detects the temperature at the core of the product. It reaches the temperature set by the user when the product is perfectly cooked both on the surface and on the inside. The core probe must be inserted deep into the food being cooked. The probe head must reach the product's core, i.e. the innermost portion, without piercing its way through the other side. If the food you are cooking is relatively thin, insert the probe parallel to the oven tray. When dealing with several foods, insert the probe into the smallest product; when this has reached the required core temperature (and therefore cooking is stopped) take the product out of the oven, insert the probe into the smallest remaining piece and restart the cooking cycle.

- ⊕ Handle the probe with care because it is extremely sharp and, after use, the needle is very hot.
- ⊕ Extract the core probe from the food before removing the trays from the oven, and place it in the external probe holder (never leave it dangling inside/outside the oven cavity).
- ⊕ Before removing the tray, check that the probe cable is not in the way.
- ⊕ Before starting preheating for a program requiring use of the core probe, position the probe in the external probe holder.

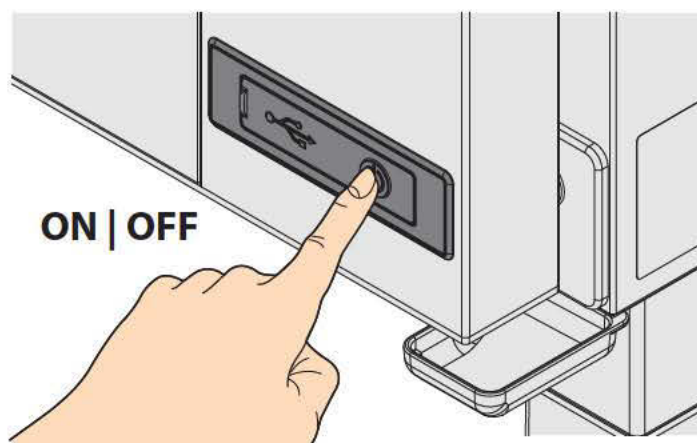
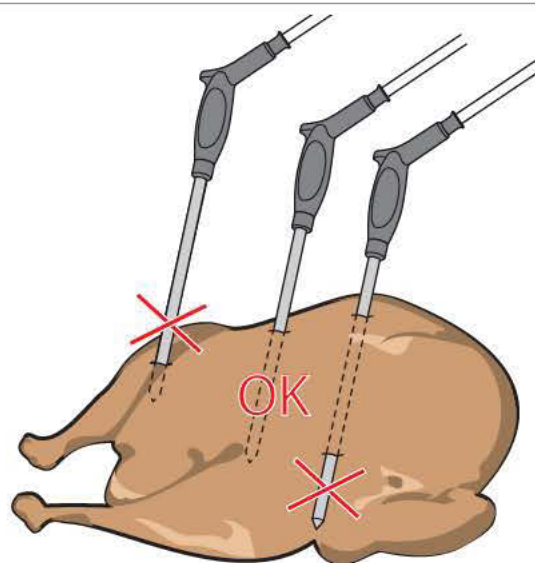
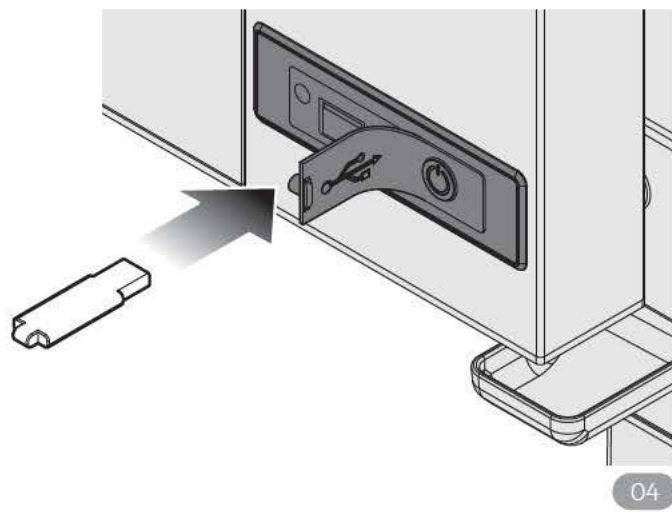

SWITCHING THE APPLIANCE ON/OFF

06 ▶ Press this button to switch the display on and off (not the oven).

To switch off the oven, turn the switch on the electrical panel to OFF.

LCD CONTROL PANEL | HOME screen

SET

This allows cooking cycles in which the user has to set the parameters manually for each cycle (e.g. temperature, cooking time, etc.).

More information on [page 16](#)

ROTOR.KLEAN

This provides access to a list of washes and lets you start the most suitable wash for your needs.

More information on [page 34](#)

MIND MAPS

A new simple, quick and intuitive way to set cooking parameters.

PROGRAMS

This menu provides access to a list of cooking cycles saved previously using the "set menu".

More information on [page 30](#)

User parameter settings (date/time, unit of measurement, etc.)

More information on [page 30](#)

This oven allows you to control the connected accessories with one control panel (e.g. SLOWTOP).

Tap the lower icon to use them.



Time and date



Wi-Fi connection active



Ethernet connection active



Wi-Fi connection NOT active



Ethernet connection NOT active

HOW TO SET VALUES

07 ▶ Drag the cursor

- ① Tap the symbol of the parameter to be set; this then changes colour (in the case of the "duration" parameter, tap hours, minutes or seconds separately).
- ② Tap the horizontal bar (this lights up) and drag the slider to the desired value; after three seconds of inactivity, the slider bar disappears.

08 ▶ Buttons

- ① Tap the symbol of the parameter to be set; this then changes colour (in the case of the "duration" parameter, tap hours, minutes or seconds separately).
- ② Use the **-** **+** buttons to modify the value.



07



08

HOW TO RETURN TO A PREVIOUS SCREEN OR THE HOME SCREEN

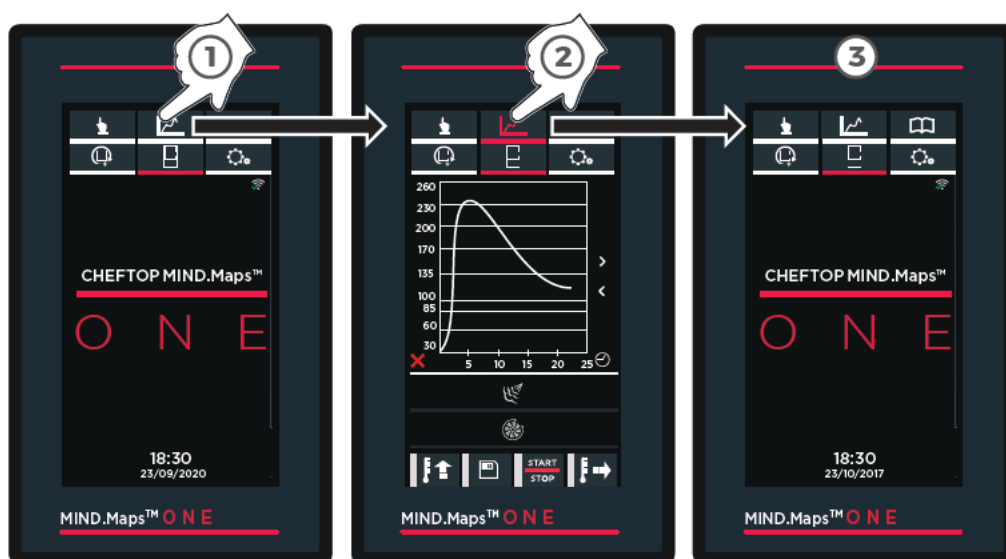

To return to the HOME screen from one of the menus (e.g. MIND.Maps), tap the icon shown in red again.

09

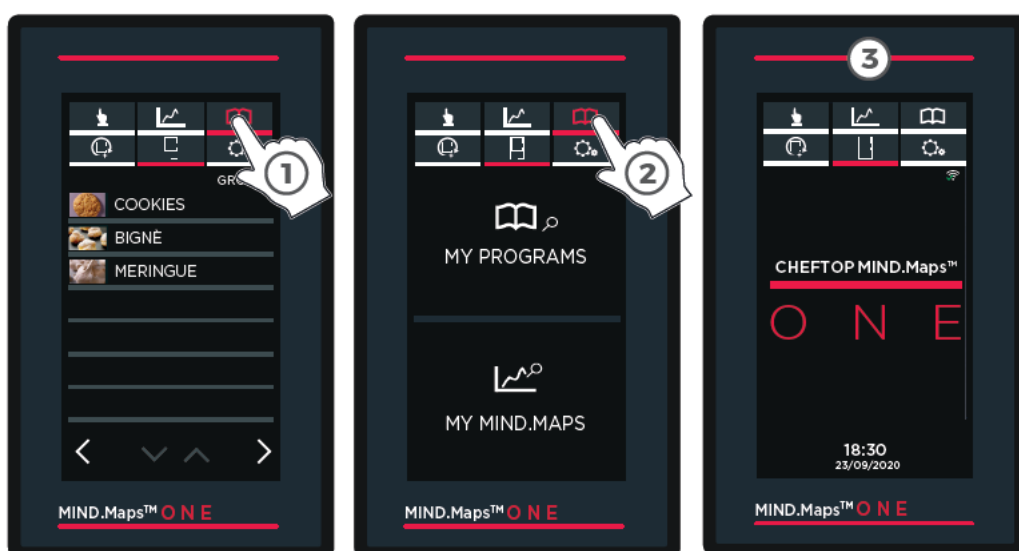

If a menu provides access to multiple pages (e.g. the SETTINGS menu), tap the menu icon multiple times to go back one page at a time until you reach the HOME screen.

10

Use | SET menu



Preheating	18
Setting the cooking steps	18
Starting the cooking cycle directly without saving it	19
Save and start the set cooking cycle	20
Cooking cycle in progress	23
Cooking end	24

For manual cooking, based on experience, you must set the following parameters for preheating and each cooking step:

- **cooking time** or **core temperature** (the two parameters reciprocally exclude each other);
- **temperature in oven cavity** or **Delta "T"** (each of these parameters reciprocally excludes the other);
- **steam input/extraction** in the cavity;
- **fan speed**.

Each manual cooking cycle is always composed of:

- ► p. 18 | an automatic **preheating**, manual setting or SMART. Preheating cycle (recommended mode);
- ► p. 18 | **up to nine steps** for cooking, each with its own cooking parameters. The appliance automatically passes from one cooking step to the next, if present. Here is an example:



After having set all the parameters (time, temperature, etc.), it is possible to **directly start cooking without saving** ► p. 19 or **save the recipe and then start the cooking cycle** ► p. 20.

Tap the BUZZER icon to enable/disable the beep at the end of each step
green = beep ON
white = beep OFF

STEP
This icon shows the number of steps being set.

Core temperature
Setting the target core temperature

 For more details, see [page 12](#)

Cooking time
(from 0 minutes to 9h:59min:59sec then INDEFINITE, i.e. the oven operates continuously)

Oven cavity temperature
(from 30°C to 260°C).

STEAM.Maxi™
Steam input to cavity

Fan speed normal or, where applicable,

access the preheating settings or go back to the previous step

Start the set cooking cycle

Save the parameters set

 For more details, see [page 20](#)

Delta "T" temperature
(from 0°C to 120°C)
Temp. in cavity/Core temp. = Temp. Delta "T"

DRY.Maxi™
steam extraction from cavity

Pulsed air-flow speed (the fan turns off when the oven has reached the temperature) or, where applicable,

Set steps 1 to 9

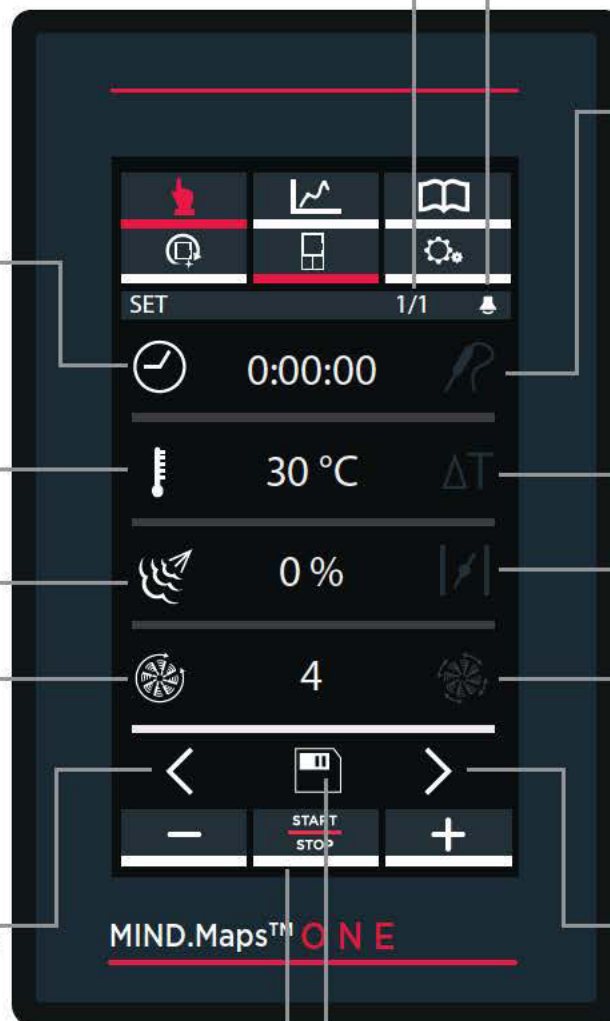

PREHEATING

Most cooking requires preheating which is optional but is always recommended to achieve the best cooking results.

12 ▶ To set the preheating temperature manually:

- 1 Tap the  icon: the settings screen appears.
- 2 Set the preheating **temperature** ▶ it is always recommended to preheat the oven to a temperature at least 20-30°C higher than the temperature required for cooking, to reduce the effects of heat lost when opening the door.
- 3 Go to the settings for step 1. To enable use, a cooking cycle must contain at least one step.



11

SETTING THE COOKING STEPS

11 ▶ Set one or more than one cooking step

- 1 Set, according to need:
 - the **cooking time** (from 0 minutes to 9h:59min:59sec then INDEFINITE, i.e. the oven operates continuously) or the **core probe temperature** ▶ page 12): each of these parameters reciprocally excludes the other. In the first case (time), the cooking cycle ends after the set time; in the second case (core probe), the cooking cycle ends when the set core temperature is reached.
 - the **cooking temperature** (from 30°C to 260°C). For particularly delicate cooking cycles, the Delta "T" function (from 0°C to 120°C) can be used as an alternative. In this case, you need to insert a core probe into the core of the food. By definition, Delta T maintains a constant temperature difference between the temperature in the cavity and the core probe temperature, using the formula: cavity temperature minus core probe temperature. Delta T can only be used by setting a core probe temperature target, not a duration.
Example: if Delta T = 80°C and the core probe temperature target is 70°C, the cooking cycle when the probe temperature reaches 70°C. The cavity temperature would then be 150°C (150°C-70°C = 80°C).
 - the **steam** released into (**STEAM.Maxi™**) or **removed from** (**DRY.Maxi™**) the oven cavity;
 - the **fan speed**: normal (left) or pulsed (right – the fan turns off when the oven has reached the temperature).



12

- ② If necessary, set up to nine other cooking steps in the same way. Each can be characterised by different cooking parameters. The appliance automatically passes from one cooking step to the next, if present.



After having set all the parameters (time, temperature, etc.), you can:

- **start the cooking cycle directly without saving it** ▶ p. 19
in this case the parameters set are not saved and must be entered during each subsequent cooking cycle;
- **saving a set recipe and starting a cooking cycle** ▶ page 20
this means that the recipe can be used later, at any time, without having to reset the parameters each time.

STARTING THE COOKING CYCLE DIRECTLY WITHOUT SAVING IT

13 ▶ To start the cooking cycle immediately, tap **START/STOP**; in this case the parameters set are not saved and must be entered during each subsequent cooking cycle.

Then go to p. 23.

- ⊕ At the end of the set time, the recipe can be saved by pressing "SAVE", see fig. ▶ 20.



SAVE AND START THE SET COOKING CYCLE

Saving a cooking cycle means that it can be used later, at any time, without having to reset the parameters each time.

The cooking cycle can be saved:

- **immediately after having set the cooking parameters** (time, temperature, etc.). In this case, you can start it by pressing **START/STOP**;
- **at the end of the cooking cycle**, by pressing "SAVE", see fig. ► 20.

14 ► To save the recipe which has just been set:

① press "SAVE".

15 ► The screen will show:

- ② assign **a name** to the recipe (e.g. CROISSANT);
- ③ tap the camera symbol to select **an image** for the program;
- ④ assign **a tray** to the recipe, selecting from those available; move between the various groups of images using the arrows at the bottom of the screen.

⑤ Press "SAVE" to save the cooking cycle with the parameters set (name, photo, etc);

⑥ tap the **position** where you want to save the cooking cycle (e.g. under "BEIGNET"). If you select a position that is already occupied, the program requests authorisation to overwrite the recipe.

At the bottom of the screen:

- the arrows < and > are used to scroll through the 16 available **groups**;
- the arrows v and ^ are used to scroll through the 16 **positions** available in the group.

The cooking cycle will be saved with the settings entered.

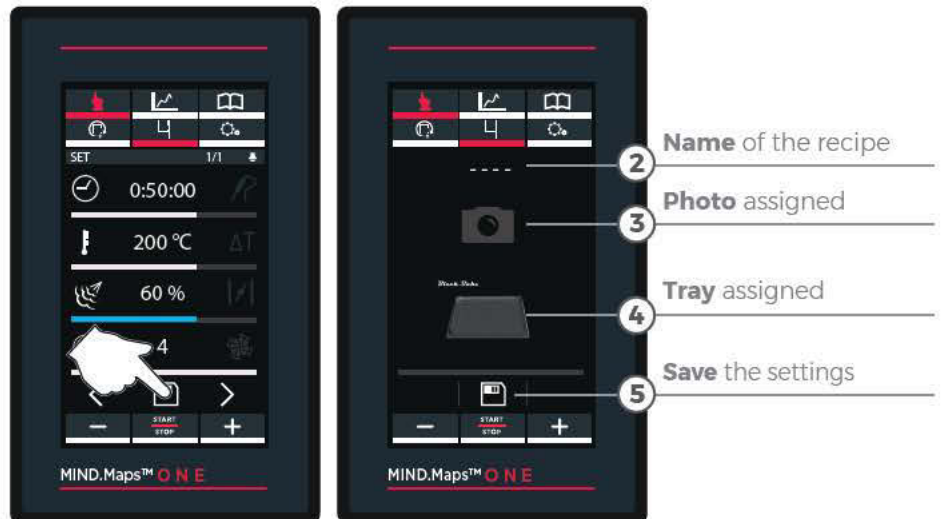

14



Assign a name to the recipe



Assign a photo to the recipe

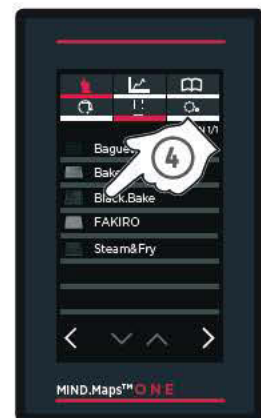

Assign a tray to the recipe



Save the settings



Assign a position for the recipe

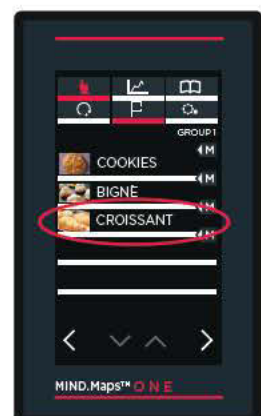

The recipe has been saved correctly

15

- 16 ▶ Tap one of the cooking cycles listed to open the screen that enables you to:
- ① **display/modify** the parameters of the saved cooking cycle;
 - ② **copy** the cooking cycle (to create one with similar parameters);
 - ③ **delete** a saved cooking cycle: in this case the system requests confirmation before permanently deleting the item;
 - ④ **save** a cooking cycle with the **START/STOP** button.



16

WHAT HAPPENS AFTER A COOKING CYCLE IS STARTED?

After starting a cooking cycle, there are three possible situations depending on the settings which have been entered previously:

- ▶ p. 21 | **preheating of the cavity not required;**
- ▶ p. 22 | **automatic or manual preheating starts;**

17 ▶ Preheating or cooling of the cavity not required

If the oven is already at the optimum temperature for the set or selected program at the start of a cooking cycle, the oven will not preheat or cool the cavity. Instead, a screen will appear to the side prompting you to put the dishes in the oven directly. After this operation, when the oven door is closed, the relevant steps automatically start ▶ p. 23.



17

18 ▶ Automatic or manual preheating function

Preheating always starts if the oven cavity is at a lower temperature than the temperature set for the first step of the cooking cycle.

If, during parameter setting:

- NO manual preheating has been set, **automatic preheating** of the cavity will start in any case and will end when the temperature set for step 1 is reached;
- **manual** preheating has been set, it will end when the temperature set by the user has been reached.

In both cases, do not put the dishes into the oven immediately, but wait until this first step ends. This will be indicated by a beep and the relative screen. After this operation, when the oven door is closed, the relevant steps automatically start ▶ p. 23.

⊕ Where necessary, a preheating cycle can always be interrupted

by pressing button . You can then move directly to the first programmed step. Please note that once a preheating cycle has been interrupted, it CANNOT be reactivated.

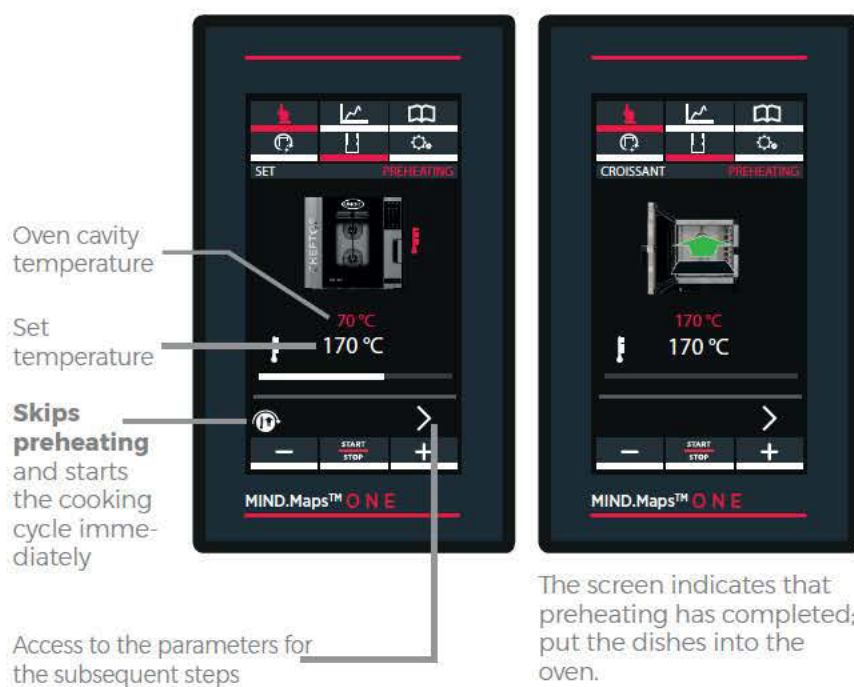

18

A | Further information

Consumption readings



From the cooking end screen, click on the  button to display the electricity and water consumption data, as well as the HACCP data.

Screen lock



Screen locked

If the oven door is opened, the screen to the side indicates that it is not possible to use the display for safety reasons.

When the door is closed or after pressing and holding the "HOME" button, the screen can be used again.

To deactivate the lock, access the USER SETTINGS menu (see p. 43).

COOKING CYCLE IN PROGRESS

19 ► Cooking is in progress. If you want to stop the cooking cycle ahead of time, press and hold the **START/STOP** button (approx. 4-5 seconds).

The steps have been set using the **duration** method.

- █ Current cooking cycle time remaining > 15 sec.
- █ Current cooking cycle time remaining < 15 sec.
- █ Cooking complete time remaining < 5 sec.

Time remaining until the end of the current step

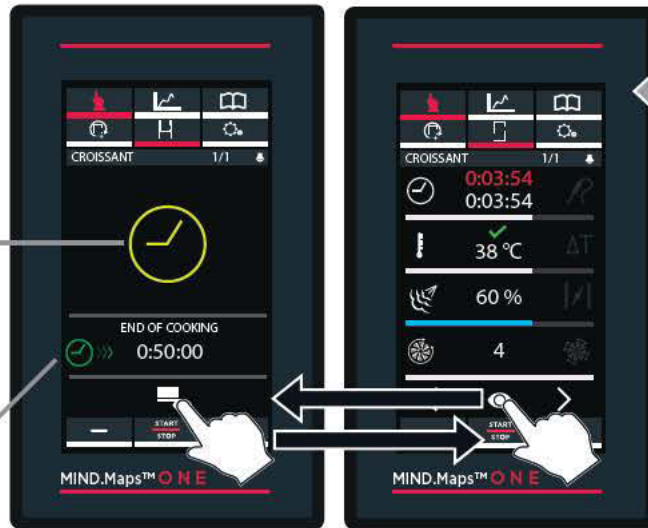

From this screen, you can **make temporary changes** to the cooking cycle in progress

The steps have been set using the **core probe** method.

- █ The difference between the temperature detected by the core probe and the set temperature is more than 5°C
- █ The difference between the temperature detected by the core probe and the set temperature is between 4°C and 2°C
- █ The difference between the temperature detected by the core probe and the set temperature is less than or equal to 1°C

temperature set on the core probe (at which point cooking is stopped)

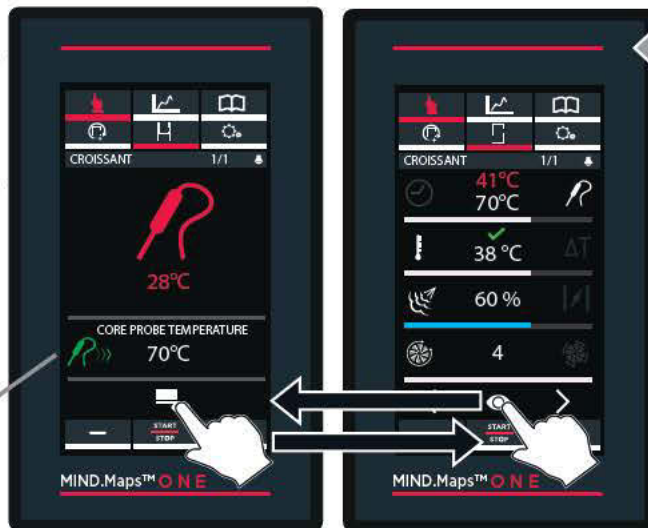

From this screen, you can **make temporary changes** to the cooking cycle in progress

ⓘ * To mute the beep, touch the icon  at the top right:
 green = beep ON
 white = beep OFF

ⓘ If you want to discontinue the cooking in progress, hold down the "START/STOP" button (approximately 4-5 seconds) until the "home" screen appears.

ⓘ To operate the oven without adding or extracting steam to adjust the humidity, set the relative humidity to 0% on the MasterTouch display.

COOKING END

20 ► Cooking ends when the set **time interval** or **core probe temperature** is reached; the end of cooking is indicated by a long beep and the relevant screen showing to the side.

From this screen you can:

- 1 **save** the completed cooking cycle (if this has not already been done)
- 2 **repeat the cooking cycle** as soon as it has finished, modifying the parameters if necessary;
- 3 **repeat the last step** carried out, modifying the parameters if necessary.
- 4 **repeat the last step** of the cycle after moving the core probe to another portion;
- 5 **repeat the last set step**, modifying the core probe temperature;
- 6 **view** the water and electricity consumption data and the HACCP data.

This screen indicates that the cooking cycle has ended (the set time has elapsed)

This screen indicates that the cooking cycle has ended (the set core temperature has been reached)

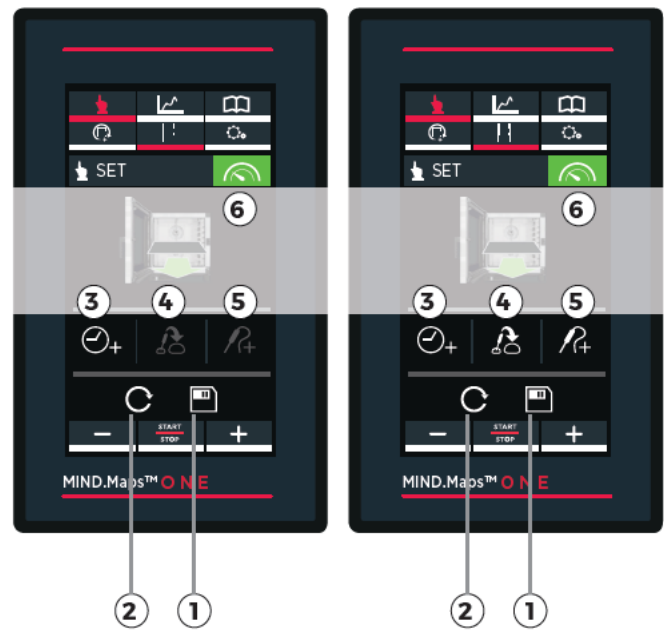

Use | MIND.Maps Menu



How MIND.Maps works	26
Setting the MIND.Maps curve	27
Subsequent parameters and saving the curve	28
Start the cooking cycle set	29

A new simple, quick and intuitive way to set cooking parameters. This menu allows you to set a parametric curve that controls the temperature, steam extraction/input and the fan speed in the cavity at all times.

Only the stylus supplied can be used to set this curve.

HOW MIND.Maps WORKS

21 ► In the example, a MIND.Maps screen is shown. The **vertical axis (Y)** shows the parameters to be set (e.g. temperature, steam input or extraction, fan speed, etc.), while the **horizontal axis (X)** shows the time ⌚.

By drawing a curve with the stylus you can modify a parameter (e.g. temperature) over time, minute by minute, giving you maximum flexibility and control.

21 ► The example shows the temperature being set based on the time:

- at 5 minutes, the temperature is set to 230°C,
- at 15 minutes the temperature should decrease to 135°C and so on.

SETTING THE MIND.Maps curve

21 ► How to draw a MIND.MAPS curve

- 1 Tap the icon "MIND.MAPS".
- 2 Use the stylus to draw the required curve. The symbol  enables access to curve settings at over 25 minutes.

22 ► Changes to the MIND.Maps curve

- 1 To **change** a part of a curve that has already been drawn, click on the curve with the stylus and, while continuing to hold it, modify the curve as desired.
- 2 To **delete** tracts of a curve already drawn, repeatedly click on the red "X" on the left.

23 ► Inserting guide rulers

- 1 To **insert rulers** that help view the values, click on the X axis in the desired position (in the example: 5 and 15 minutes): the numbers will be highlighted in grey and a green ruler will appear. The numbers above the rulers (in the example "10") show the difference in minutes compared to the previous ruler (15 minus 5 minutes = 10).
- 2 To **delete rulers**, with the numbers highlighted in grey, repeatedly click on the red "X" on the left. The rulers will be deleted in the order they were created.



21



22



23

24 ► **Zoom**

- ① To **enlarge** an interval, click on the Y axis in the desired position (in the example: an interval between 170° and 200°).
- ② Click in the Y axis again or on the symbol in the bottom left corner to return to the normal mode.

SUBSEQUENT PARAMETERS AND SAVING THE CURVE

- 25 ► ① Tap another icon to set the next parameters, **steam extraction (DRY.Maxi)** or **steam input (STEAM.Maxi)**, and **fan speed**.

- ② Trace a new curve to set the selected parameter:

DRY.Maxi or **STEAM.Maxi**:

- the extraction values are displayed in RED,
- while the input values are displayed in BLUE;

fan speed (from speed 1 - minimum, to speed 4 - maximum):

- the pulsating fan speed is shown with a dashed line (values below zero),
- the normal speed is shown with a continuous line (values above zero).

The thickness of the line also indicates the speed (a thin line shows a slow speed and a thick line shows a high speed).

- ③ To set preheating, press the **“PREHEATING”** button at the bottom right and set this step.

- ④ Press the **“SAVE”** button to save the set curve; the saving process is the same as that explained previously under **“set menu”**.

📖 For more details, see ► page 16

- ⑤ The **“HOLD”** button at the bottom right means the oven can be used continuously.

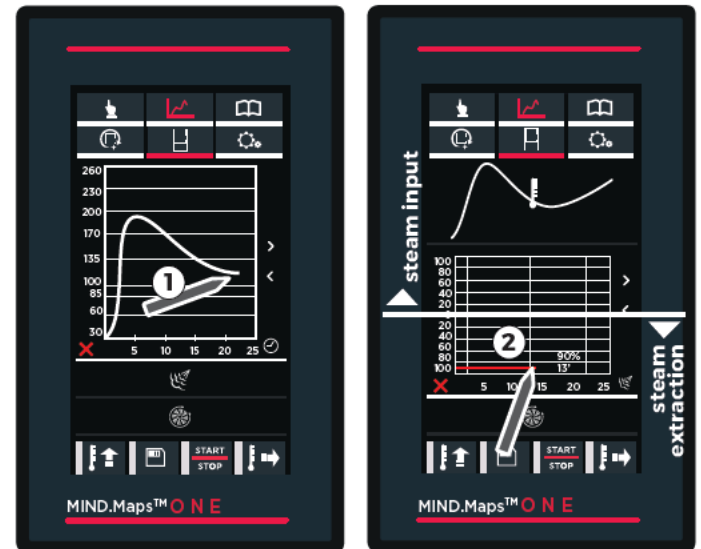
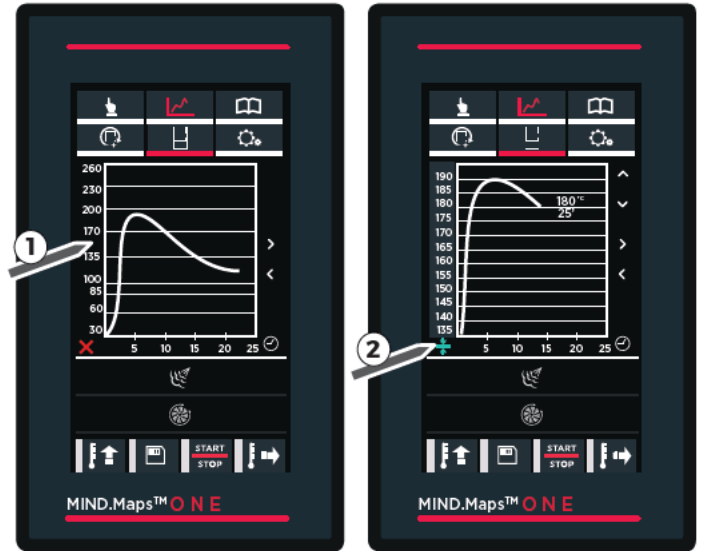

humidity input/extraction

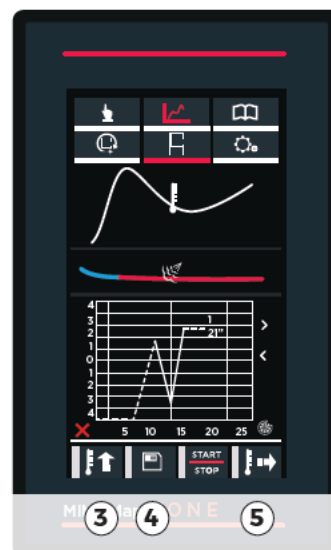

— pulsed speed
 - - - normal speed

START THE COOKING CYCLE SET

26 ▶ To start the cooking cycle, press the **START/STOP**.

▶ If the oven cavity is at a **lower temperature** than the temperature set for the first step of the cooking cycle, a **preheating cycle** starts.

If the saved cooking cycle:

- does NOT include preheating, **automatic preheating** of the cavity will start nonetheless and will end when the temperature set for step 1 is reached;
- includes **preheating**, this will end when the temperature set in the user's recipe has been reached.

Wait for this to end before putting the food in the oven. step 1 starts automatically as soon as the oven door is closed.

▶ If the oven cavity is at **the set temperature or higher** for the first cooking step, **the cooking cycle** will start with the set parameters. Put the food in the oven immediately. step 1 will start automatically as soon as the oven door is closed.



Use | PROGRAMS Menu



MY PROGRAMS	30
MY MIND.MAPS	32

This menu enables access to a list of cooking cycles saved previously.





MY PROGRAMS

In this section the user can recall a previously saved cooking cycle by using the **“SET menu”**.

 For more details, see ► page 16

27 ► ① Tap the **“programs”** icon;

② tap the **“MY PROGRAMS”** icon: a list of cooking cycles previously saved using the **“SET menu”** opens.

③ Tap one of the cooking cycles listed. At the bottom of the screen, the arrows  and  are used to scroll through the various cooking cycles saved in the group, while arrows  and  are used for scrolling through the 16 groups available.



- 28 ▶ ④ From this screen you can:
- ① view/modify the saved cooking cycle;
 - ② duplicate the cooking cycle (to create one with similar parameters);
 - ③ delete a saved cooking cycle: in this case the system requests confirmation before permanently deleting the item.

⑤ To start the cooking cycle, press the **START/STOP**.

▶ If the oven cavity is at a **lower temperature** than the temperature set for the first step of the cooking cycle, a **preheating cycle** starts.

If the saved cooking cycle:

- does NOT include preheating, **automatic preheating** of the cavity will start nonetheless and will end when the temperature set for step 1 is reached;
- includes **preheating**, this will end when the temperature set in the user's recipe has been reached.

Wait for this to end before putting the food in the oven. step 1 starts automatically as soon as the oven door is closed.

▶ If the oven cavity is at **the set temperature or higher** for the first cooking step, **the cooking cycle** will start with the set parameters. Put the food in the oven immediately. step 1 will start automatically as soon as the oven door is closed.

📖 For more details, see ▶ page 21

29 ▶ When the cooking cycle is complete, a screen shows from which you can:

- ① **repeat the cooking cycle** as soon as it has finished, modifying the parameters if necessary;
- ② **repeat the last step** carried out, modifying the parameters if necessary.
- ③ **repeat the last step** of the cycle after moving the core probe to another portion;
- ④ **repeat the last set step**, modifying the core probe temperature;
- ⑤ **view** the water and electricity consumption data and the HACCP data.



if you decide to delete the recipe, a screen will request confirmation before permanently deleting the item

28



29

MY MIND.MAPS





In this section the user can recall a previously saved cooking cycle by using the **"MIND.MAPS menu"**.

For more details, see

p. 26

30 ▶ ① Tap the **"programs" icon**;

② tap the **"MY MIND.MAPS"** icon: a list of cooking cycles previously saved using the **"MIND.MAPS menu"** opens.

③ Tap one of the cooking cycles listed. At the bottom of the screen, the arrows  and  are used to scroll through the various cooking cycles saved in the group, while arrows  and  are used for scrolling through the 16 groups available.

④ and ⑤: see previous page.

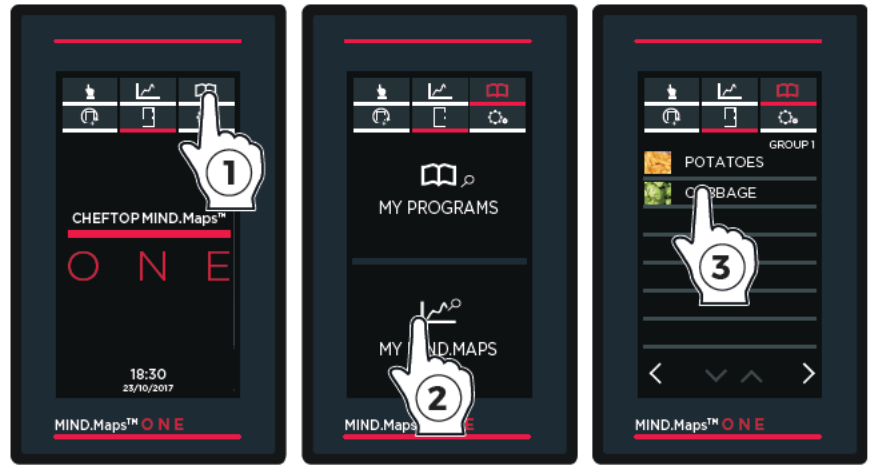

30

Use | ROTOR.KLEAN Menu



Warnings regarding washing cycles	34
How to use the washing programs (ROTOR.KLEAN)	35
Refilling detergent tank	36

Enables access to the washing list.

WARNINGS REGARDING WASHING CYCLES

The ovens come equipped with one/two rotor(s) for cleaning the oven cavity.

- ❗ Before starting a cleaning cycle, **make sure that there are NO trays** in the oven cavity, otherwise the washing cycle will be ineffective.
- ❗ **Carefully read the product safety data sheet before handling and using the detergent.**
- ❗ **Do not open the oven door during a washing cycle as this could cause injury to eyes, mucous membranes and skin caused by contact with the cleaning chemicals used. These chemicals are sprayed by the rotor in the cavity and moved by strong air currents.**
- ❗ **Do not tamper with the tank and its connections to the oven for any reason as this could cause a risk of injury or death.**
- ❗ **The detergent must not come into contact with the skin, eyes or mucous membranes. In case of contact with the detergent, follow the instructions on the safety data sheet.**
- ⚠ **Never touch the detergent with bare hands.**
- ❗ For ovens with a trolley, run the washing cycle with the trolley inside the oven cavity, without any trays and lock it using the front wheel brakes.
- ❗ Periodically check for rust stains inside the oven cavity: if they are found, contact a service centre urgently because the water is probably damaging the oven; prompt action will extend the lifespan of the equipment.



When the terminal is blocked, DO NOT use the washing programs or wash the cavity with large quantities of water. Risk of flooding.

HOW TO USE THE WASHING PROGRAMS (ROTOR.KLEAN)

In this section, start one of the following wash or rinse programs:

RINSE	00:17*	cold rinse
QUICK	01:02*	oven cavity slightly dirty
SHORT	01:09*	oven cavity slightly dirty
MEDIUM	01:27*	oven cavity dirty
LONG	02:32*	oven cavity very dirty

* Times are expressed in the format hours:minutes. They are indicative and may vary depending on the oven model.

- 31 ▶ ① Tap the Rotor.Klean icon
 ② Tap the name of the program you want to start.
 ③ Press the **START/STOP** button to start the wash cycle.

- 32 ▶ The display shows the time remaining until the end of the washing cycle.

The colour of the clock indicates:

- **red**: washing program in progress.
- **Yellow**: less than 1 minute until the selected washing program finishes
- **green**: the wash has finished, it automatically returns to the **"HOME"** page.

To **stop** a wash cycle ahead of time, press and hold the **START/STOP** button for approximately 3 seconds: a quick rinse cycle will start automatically and run for approximately **12 minutes** to remove any remaining detergent from the oven cavity.



CONSUMPTION: the screen displays the consumption data for the selected wash circle:

- water consumption (in litres);
- electrical consumption (in kW/h);
- UNOX.Det&Rinse Plus (detergent) consumption.

31

Warning: DO NOT open the door during washing.
RISK OF INJURY TO EYES, MUCOUS MEMBRANES AND SKIN CAUSED BY CONTACT WITH THE CLEANING CHEMICALS USED.



Washing complete

Washing in progress (less than 1 min. remaining)

Washing in progress (more than 1 min. remaining)

Remaining time until the end of the current program

32

REFILLING DETERGENT TANK

❗ Only fill with the 1-litre bottles of the **UNOX. Det&Rinse Plus** detergent.

33 ▶ To refill the detergent:

- **Wear gloves to prevent your hands from coming into direct contact with the detergent.**
- Pull out the tank from under the oven until you hear a “click”.
- Open the lid of the tank.
- Open the cap of the UNOX 1-litre detergent bottle without removing/piercing the protective film.
- Turn the bottle upside down and screw it on the tank (by screwing the bottle, a pin in the tank breaks the protective film, which allows the detergent to come out).
- Once the bottle is empty, unscrew it to remove it. Avoid dripping.

❗ **The detergent must not come into contact with the skin, eyes or mucous membranes. In case of contact with the detergent, follow the instructions on the safety data sheet.**

- Repeat the process up to the maximum level allowed, indicated on the front of the tank. (Maximum capacity of the 4 litre tank = 4 bottles).
- Remove the bottle.
- Reposition the tank under the oven until it stops.
- Dispose of the gloves, taking care not to touch the areas spoiled with detergent.

⚠ **Never touch the detergent with bare hands.**

33 ▶ Once loading is complete, start the PUMP LOADING program. this program lasts about 25 seconds and serves to load the detergent from the tank and remove air from the suction tube. At the end of the loading program, you MUST start one of the wash cycles (e.g. QUICK).

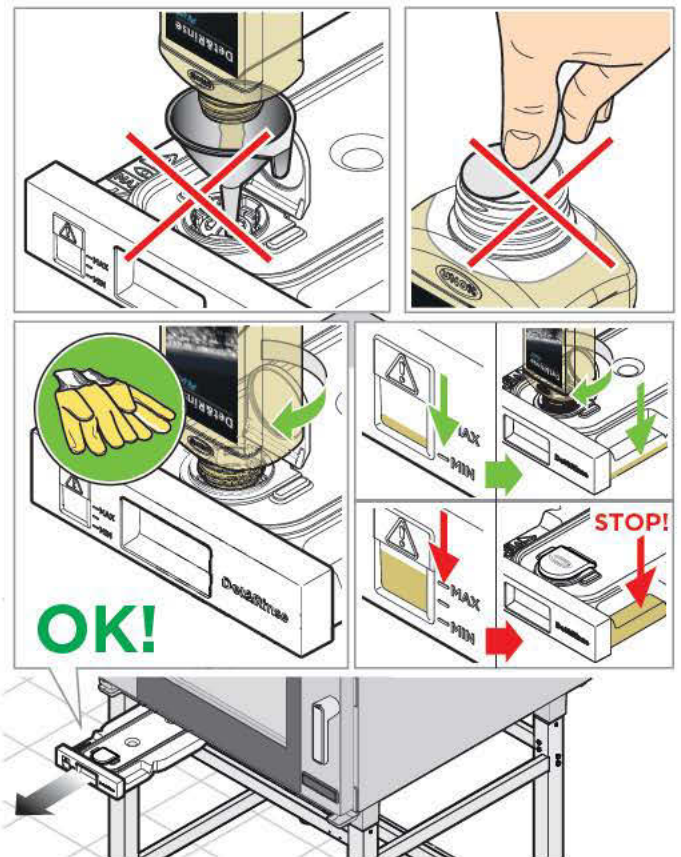

33



34

Menu settings



Language	39
Date and time	39
Unit of measurement	39
Network	40
Consumable prices	40
USB	41
Unox.Care	42
Options	43

35 ► The USER MENU provides access to the oven parameter settings.



The SERVICE MENU is for specialist operators only, whereas the “USER SETTINGS” can be accessed by any operator by entering the password “4456” and confirming with “OK”.

The NETWORK MENU allows you to enable or disable oven control via remote network access and configure the relevant parameters.

► For more details, see page 40



LANGUAGE

36 ► Here you can select the language, which will be used for all menu entries. You can scroll through the list of available languages using the arrows  and .



Simply tap a language to select it.



36

DATE AND TIME

37 ► This lets you modify the date and time settings of the menu. It is necessary to:

- set the **Time zone**, clicking on the relevant geographic area and selecting the country, scrolling through the list using the arrows  and .
- enter the current standard clock time as **winter time** (also called standard time) or **summer time** (also called daylight saving time); alternatively, the "AUTOMATIC" setting allows the time to be updated automatically;
- set the current **time, year, month** and **day**.

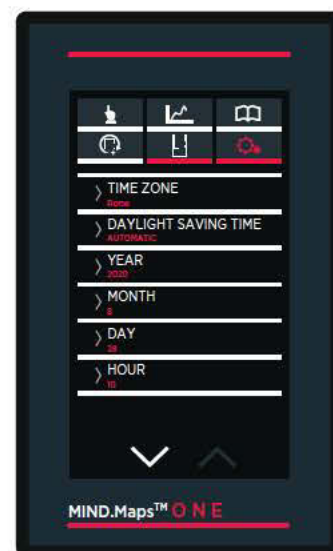

37

UNIT OF MEASUREMENT

38 ► Select the unit of measurement for the:

- **temperature** (°C/°F);
- **volume** (litres or gallons);
- **thickness** (mm or inches);
- **weight** (kg or pounds);
- **energy** (kWh or BTU).

It also allows you to set the **current currency** (€, \$, etc.), and, by entering this menu, you can also set:

- whether the currency symbol should come before or after the value (symbol position);
- whether to use a decimal point "." or comma "," in decimal numbers (decimal sign).

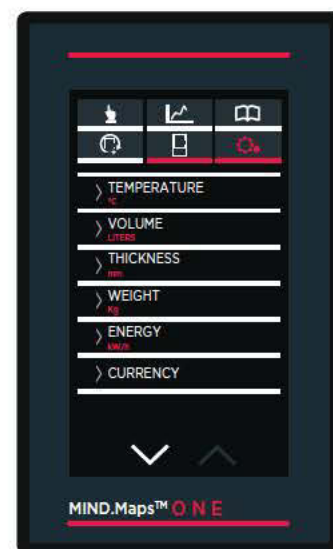

38

NETWORK

39 ▶ This menu enables or disables oven control via remote network access and allows you to configure the relevant parameters.

Connection test

Connection test for both types of connection.

Wi-Fi network: tap here to select the network to connect to (or to enter it manually).

Wi-Fi password: tap here to enter the Wi-Fi password.

Cloud PIN

The PIN code needed to connect the oven with DDC.unox.com and the app. Each oven has its own pre-set PIN code. The PIN code can be modified to connect to a personal DDC account; in this case, the oven must be paired.

DHCP

This allows you to obtain the network settings from the DHCP server (for Wi-Fi connections, always leave the DHCP set to "ON").

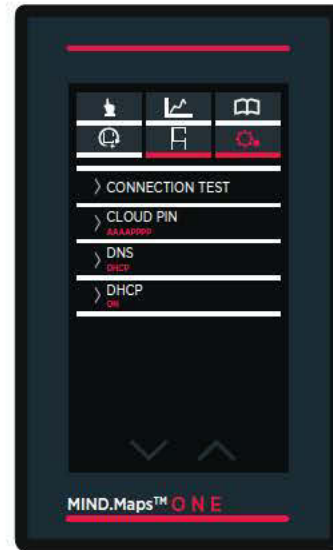

39

CONSUMABLE PRICES

40 ▶

It allows you to enter the cost of **electricity**, **water** and **detergent** (the currency is the one set in the "Unit of measurement" section on this screen)

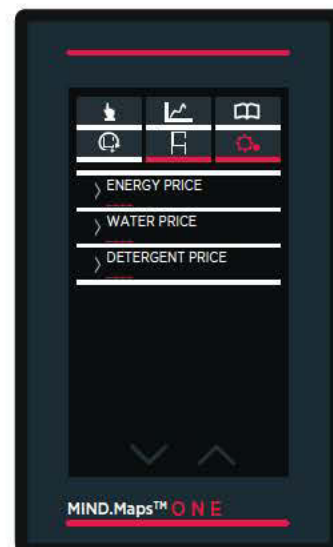

40

USB

41 ▶ This section allows you to import or export materials from your own USB stick (FT32 formatted and with capacity between 4 and 16 GB). The USB port is located below the LCD panel and allows you to import or export materials from your own USB stick (FT32 formatted and with capacity between 4 and 16 GB).

- EXPORT PROGRAMS ▶ exports recipes from the oven to a USB stick;
- IMPORT PROGRAMS ▶ imports recipes from the USB stick to the oven;
- IMPORT PICTURES ▶ imports pictures from the USB stick to the oven, e.g. an image of one of your particularly successful dishes. To be used, the images must be converted: see ▶ 42
- EXPORT HACCP TO USB ▶ export the HACCP data detected by the oven to a USB stick.



41

- 1 Download the UNOXDIR.zip folder from the software section of UNOX Infonet
- 2 Save the UNOXDIR.zip folder onto your USB stick
- 3 Unzip the UNOXDIR.zip folder that you have just downloaded
- 4 Open the UNOXDIR folder
- 5 There are two folders inside this folder (ZDATA and IMAGES) as well as an .exe file (IMAGECONVERTER.EXE)
- 6 Copy the images you want to use in the IMAGE folder
- 7 Start the IMAGECONVERTER.EXE program. You can now use the images!

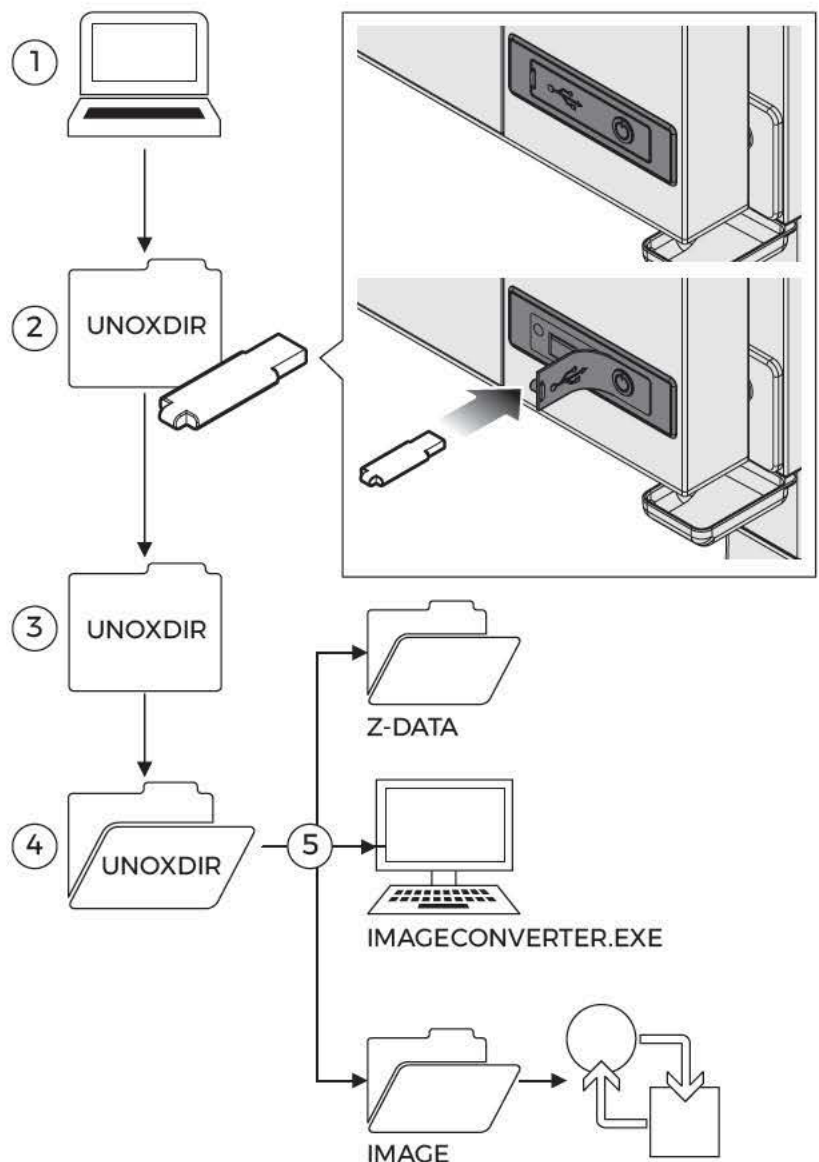

UNOX.CARE

43 ▶

UNOX.Pure | UNOX.Finest | BAKERY.Pure

① Remaining volume

Thanks to an internal litre counter (which has to be reset each time the filter is changed), the user can find out at any given moment how many litres of incoming water remain until the filter will next need changing (in the example: 7,083 litres remaining until the filter needs replacing).

② Temporary water hardness

The hardness of the water can be set on this screen within a range of 3°dH to 10°dH (German degrees). It can be measured with the orange test kit.

③ Activating the counter

After having replaced the filter, the litre counter must be reset so that it starts counting from zero again. To carry out this operation, enter the PIN code identified on the kit box.

UNOX.PURE-RO

① Remaining volume

Thanks to an internal litre counter (which has to be reset each time the filter is changed), the user can find out at any given moment how many litres of incoming water remain until the filter will next need changing (in the example: 7,083 litres remaining until the filter needs replacing).

② Total water hardness

The hardness of the water can be set on this screen within a range of 3°dH to 10°dH (German degrees). It can be measured with the green test kit.

③ Activating the counter

In order for the OSMOSI system to work properly, this parameter must be set to "ON" (default is "OFF"). If, for any reason, the reverse osmosis system is removed from the oven, or while waiting for a repair, set it back to "OFF".

④ Resetting the counter

After having replaced the filter, the litre counter must be reset so that it starts counting from zero again. To do this, you need to access the screen and confirm with the "X" (DELETE).



43

OPTIONS

44 ▶

Consumables

When active (ON), it converts consumption data (e.g. litres used for steam) into costs, based on the currency set.

Lock user program

This allows you to start and display the cooking programs stored by users but prevents them from being edited and deleted.

Lock manual cooking cycles

Blocks the possibility of manual cooking (SET menu).

Lock program view

This allows you to start the cooking programs stored by users but prevents them from being displayed, edited and deleted.

Seconds to show slides in cooking

Sets the number of seconds after which, with no interaction with the display, the screen with the cooking cycle in progress is displayed.

Lock screen timeout

If the oven door is opened, the screen to the side indicates that it is not possible to use the display for safety reasons. When the door is closed or after pressing and holding the "HOME" button, the screen can be used again. If the set value is:

- = "0" ▶ no screen appears even if the door is open;
- ≠ "0" ▶ the set value indicates the number of seconds after which the display unlocks once the door is closed. For example, if the value is set to "5", the panel will unlock 5 seconds after the door has been closed.

SAFE.Lock

Set the number of seconds of inactivity after which the control panel locks automatically. To unlock it, enter the numeric code which is set under the SAFE.Lock PIN menu.

SAFE.Lock PIN

Enter a numeric code to unlock the control panel.



44



45

Alarms and warnings | User oven interface

The ovens show any alarm/warning messages relating to the oven or installed accessories on the screen. The **WARNING messages** signal malfunctions that allow the appliance/accessories to continue operating, but with a restricted set of functions.

The **ALARM** messages identify issues which prevent any operation of the appliances/accessories, which therefore must be put into STOP mode.

If the alarm messages refer to the connected accessories only, the oven can still be used.

Maintenance

Safety information for maintaining the appliance	46
Cleaning the appliance	47
Inactivity	48
Disposal	48
Certification	49

SAFETY INFORMATION FOR MAINTAINING THE APPLIANCE

- ⚠ Any routine maintenance must be performed:
 - after disconnecting the appliance from the power supply and waiting for the capacitive components to discharge (approx. a few minutes);
 - after waiting for the appliance to cool down fully;
 - only if you are in good mental and physical condition, and are wearing suitable personal protective equipment (e.g. heat-resistant rubber gloves, eye protection, dust mask (optional), etc.).

Clean the appliance on a daily basis in order to maintain a good level of hygiene and to prevent the stainless steel from corroding or deteriorating.

⚠ Daily cleaning also reduces the possibility of accumulated fatty substances or food residues inside the cavity catching fire and becoming a fire hazard.

When cleaning any component or accessory NEVER use:

- abrasive, pointy or sharp tools or cloths (abrasive sponges, scrapers, steel-bristled brushes, etc.);
- steam or pressurised water jets;
- abrasive or powder detergents;
- alkaline, aggressive, caustic or corrosive detergents (e.g. hydrochloric/muriatic or sulphuric acid or caustic soda). These substances could cause permanent damage to the appliance surfaces and catalysts.

⚠ Never use these substances when cleaning the appliance substructure or the floor under the appliance. The volatile emissions from these compounds may still cause damage.

CLEANING THE APPLIANCE

External steel structures, oven cavity seal, core probe

- ⚠ Wait for the surfaces to cool off.
Use only a soft cleaning cloth dampened with soapy water. Rinse and dry thoroughly. Alternatively, only use detergents recommended by UNOX; other products may cause damage, thereby invalidating the warranty*. Read the usage instructions provided by the detergent manufacturer.

Inside the oven cavity

- ⚠ **Failure to clean the oven cavity daily can cause the accumulated grease and food residues inside to catch fire - this is a fire hazard.** Use the washing cycle programs to clean the oven cavity.

📖 For more details, see ► page 35



46



When the terminal is blocked, DO NOT use the washing programs or wash the cavity with large quantities of water. Risk of flooding.

Plastic surfaces and control panel

- ⚠ Wait for the surfaces to cool off. Use only a very soft cleaning cloth and a small amount of detergent to clean delicate surfaces.

Oven door internal and external glass

- ⚠ Wait for the surfaces to cool off.
Only use a soft cleaning cloth dampened with soap and water or a specific glass cleaner. Rinse and dry thoroughly.

INACTIVITY

During periods of inactivity, take the following precautions:

- disconnect the power, water and gas supplies to the appliance (ONLY FOR GAS OVENS);
- preferably rub a soft cloth lightly doused with Vaseline oil on all stainless steel surfaces;
- keep the appliance door slightly ajar.

Before reusing the appliance:

- clean the appliance and accessories thoroughly (see page 47);
- reconnect the appliance to the power, water and gas supplies (GAS ONLY FOR GAS OVENS);
- inspect the appliance before using it again;
- switch on the appliance at minimum temperature for at least 50 minutes without any food inside.

 To ensure that the appliance is in perfect condition in terms of use and safety, maintenance and inspections should be performed at least yearly by an authorised support service centre.

DISPOSAL

Pursuant to article 13 of Italian Legislative Decree 49 of 2014 "Implementation of the WEEE Directive 2012/19/EU on waste electrical and electronic equipment"



The crossed-out wheeled bin symbol indicates that the product was placed on the market after 13 August 2005 and that, at the end of its useful life, it should not be disposed of with other waste, but must be collected separately.

All appliances are made with recyclable metals (stainless steel, iron, aluminium, galvanized steel, copper, etc.) in percentages above 90% by weight.

Before disposal, ensure the appliance is unusable by removing the power cable and all compartment or cavity closure devices (where present).

At the end of its useful life, the product must be disposed of in such a way as to reduce any negative impact on the environment and make efficient use of available resources. Prefer prevention, preparation for reuse, recycling and reclamation, and remember "the polluter pays". Please remember that illegal or incorrect disposal of the product incurs penalties, as provided for by current legislation.

Information on disposal in Italy

In Italy, WEEE appliances must be delivered to:

- recycling centres (also known as waste disposal sites/facilities)
- the dealer from whom a new appliance is purchased, who is required to collect them free of charge ("one-for-one" exchange);

Information on disposal in European Union countries

The EU Directive on WEEE appliances has been implemented differently by each country. Therefore, if you want to dispose of this appliance, we recommend you contact your local authority or dealer for information on the correct disposal method.

CERTIFICATION

EU declaration of conformity for electrical and gas appliances

Manufacturer: UNOX S.p.A.

Address: Via Majorana, 22 - 35010 Cadoneghe, Padua, Italy

Declares, under its own responsibility, that the product

CHEFTOP-BAKERTOP MIND.Maps™

For electric ovens:

complies with the Machinery Directive 2006/42/EC through the following standards:

EN 60335-1: 2014 + A11:2014 + A13:2017

EN 60335-2-42: 2003 + A1: 2008 + A11:2012

EN62233: 2008

EN 60335-2-102:2006 + A1:2010

complies with the Electromagnetic Compatibility Directive 2014/30/EC through the following standards:

EN 55014-1: 2006 + A1: 2009 + A2: 2011

EN 55014-2: 1997 + A1: 2001 + A2: 2008

EN 61000-3-2: 2006 + A1: 2009 + A2: 2009

EN 61000-3-3: 2008

EN 61000-3-11: 2000

EN 61000-3-12: 2011

Support

After-sales assistance

50

AFTER-SALES ASSISTANCE

In case of any malfunctions, disconnect the appliance from the power supply and consult the solutions proposed in the table **B | Troubleshooting** on page **51**.

If the solution is not listed in the table, contact an authorised UNOX technical service centre, providing the following information:

- date of purchase;
- **47** ► the appliance data on the serial plate;
- any warning messages that appear on the display.

Manufacturer's information:

UNOX S.p.A.

Via Majorana, 22

35010 Cadoneghe (PD), Italy

Tel. (+39) 049 8657511 - Fax (+39) 049 8657555

info@unox.com www.unox.com

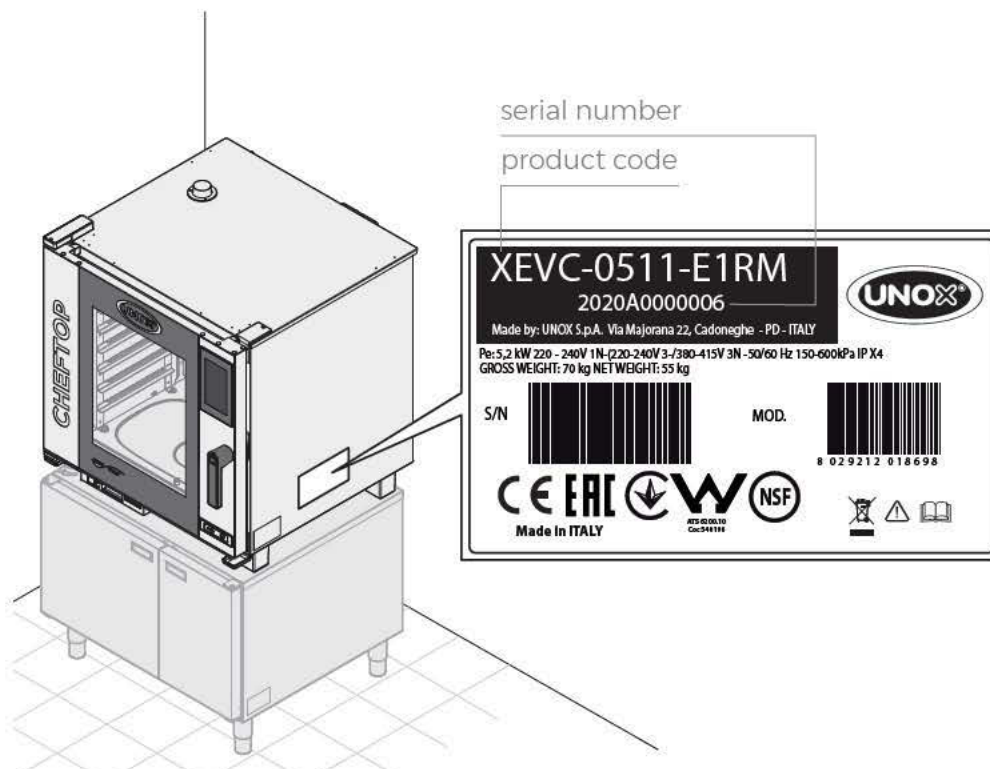

B | Troubleshooting

Fault	Possible cause	Possible solution	Solution
The oven is completely switched off.	<ul style="list-style-type: none">■ No mains power.■ Appliance out of order.	Make sure the appliance is connected to the electricity mains.	Contact the Customer Assistance Service.
No steam is produced inside the oven cavity.	<ul style="list-style-type: none">■ Water inlet closed.■ Appliance plumbed into the water mains or the tank incorrectly.■ No water in the tank (if water is taken from the tank).■ Water supply filter clogged with impurities.	<ul style="list-style-type: none">■ Open water inlet.■ Make sure the appliance is plumbed into the water mains or the tank correctly.■ Fill the tank with water.■ Clean the filter.	Contact the Customer Assistance Service.
After setting the time and pressing the START/STOP button, the oven does not start.	<ul style="list-style-type: none">■ Door open or not shut properly.	<ul style="list-style-type: none">■ Make sure the door is shut.	Contact the Customer Assistance Service.
Water leaks through the seal when the door is shut.	<ul style="list-style-type: none">■ Seal dirty.■ Seal damaged.■ Handle mechanism is loose.	<ul style="list-style-type: none">■ Clean the seal using a damp cloth.■ Contact a specialist technician for repair.	Contact the Customer Assistance Service.

