

ALFA425H-2

Family	Ovens
Subfamily	4 trays 600x400 mm o GN1/1
Oven type	Fan with humidification
Oven control	Mechanical
Trays capacity	4 trays 600x400 mm - GN1/1
Power supply	400 V 3N~ / 17 A / 6,9 kW / 50 Hz
Other electrical connection	230 V~ / 30 A / 6.9 kW / 50Hz
Steam generation	Direct
WiFi connection	Not available
Width	798 mm
Depth	747 mm
Height	563 mm
Maximum depth with open door	1511 mm
Adjustable feet	Yes
Net weight	60,000 kg



Distribution

Solutions	Bars/Cafes; Hotels; Restaurants/Catering; Bakery/Pastry making; Industrial pastry&bakery laboratories; Butcher's shops; QSR	Suggested for	Bars/Cafes
------------------	--	----------------------	------------

Aesthetics

Colour	Stainless steel	Front panel	Yes
Door with stainless steel stripes	Yes	Logo	Smeg printed

Controls

Timer setting range	1-60 minutes + endless
----------------------------	------------------------

Programs / Functions

Backing functions



Fan forced



Fan forced with humidification

Options

Construction

Oven materials	Ever Clean enamel	Humidification levels	Manual
Cavity dimensions (lxdxh)	672x437x340mm	Exhaust position	Back
Gross volume	670x560x420mm	Components cooling system	Yes
Net volume	670x560x420mm	Timer type	Electromechanical timer
Internal net volume	670x560x420mm	Temperature range	50-270°C
Cavity material	Stainless steel	End cooking signal	Yes
Shelves number	4	Orange light indicator t° achievement	Yes
Tray frame support	Chrome	Green light indicator t° achievement	Yes
Shelves distance	77 mm	Manual reset safety thermostat	Yes
Door construction	Double glass	Removable deflector	Yes
Door opening	Lateral	Lighting	2 LED lamps
Handle type	New ergonomics	Light power	40 W
Openable glass	Openable	Water load pipe	Yes
Fan type and number	2 contrarotating fans with time direction reversal	Power cable length	170 cm
Engine speed	Ever Clean enamel	Back panel	Galvanized
Engine speed	Single speed	IPX protection	Scheduled start H/12
Max standard speed motor rpm	2		

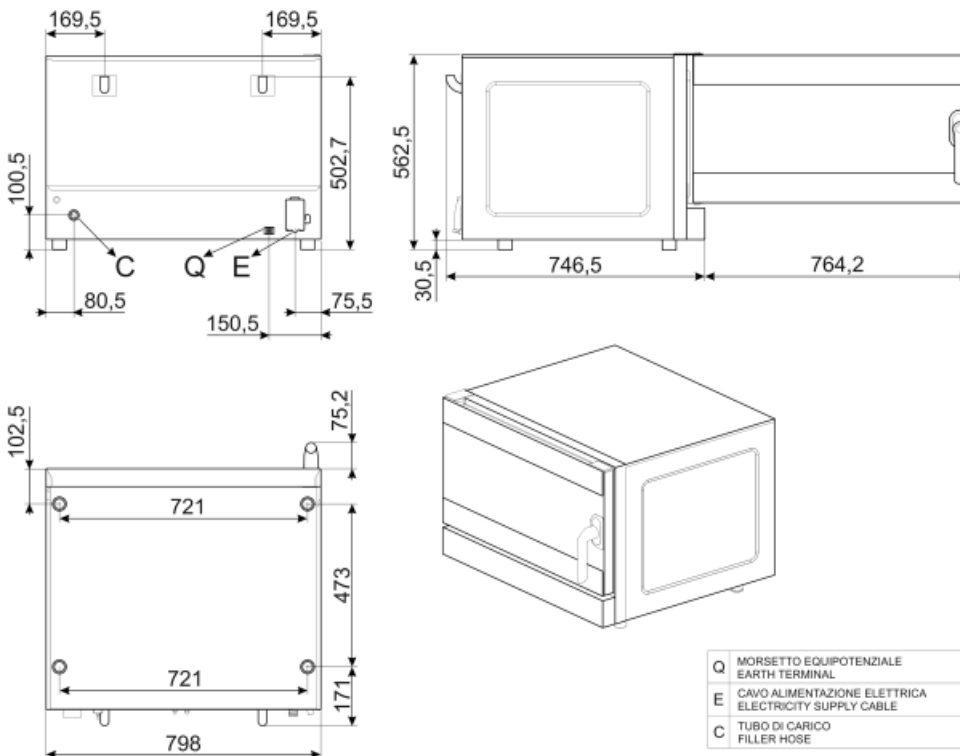

Not included accessories



3805

Flat chrome-plated wire grid



3927

Air flow reducer kit



3743

Flat aluminium tray

RGN11-420-2

Support kit for grids or flat trays
GN1/1 suitable for ALFA420/425
models

SVRPP625

Conjunction kit for 2 ovens series
625/420 and hood

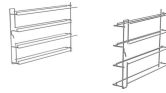

RGN11-420

Support kit for flat trays GN1/1



3751

Flat perforated aluminium tray

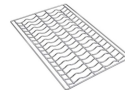

3810

Corrugated grid for baguettes

SVRPP420

Conjunction kit between 2 ovens series
420/425 and hood

Symbols glossary (TT)



...



...