



# VACUUM PACKING MACHINE SE-810 LL 400/50-60/3N

Floorstanding unit. 100 m³/h. 848+848 mm.



P/N 1140698



## INCLUDES

- ✓ Sensor Controls
- ✓ Up to 10 seconds of extra vacuum pull
- ✓ Soft air function
- ✓ Dry oil cycle
- ✓ BUSCH pump
- ✓ NSF Approved
- ✓ Clear methacrylate lid
- ✓ Filling plate

## ACCESSORIES

- Bag cutting kits
- Filling plates
- Liquid insert plates
- Vac-norm external vacuum kits
- Vac-norm containers
- Smooth bags for vacuum packing

## SALES DESCRIPTION

Two sealing bars (848+848 mm.)  
 63 m³/h Busch vacuum pump.  
 Vacuum controlled by sensor.

- ✓ Powered by Busch.
- ✓ Vacuum controlled by sensor.
- ✓ Vacuum PLUS.
- ✓ Digital keyboard.
- ✓ Control panel equipped with display indicating the exact vacuum percentage.
- ✓ "Pause" button to marinate food.
- ✓ Safe liquid packing thanks to sensor control.
- ✓ Double seal.
- ✓ Cordless sealing bar.
- ✓ Bag-sealing programme.
- ✓ Pulse-controlled decompression.
- ✓ Vac-Norm ready with Automatic decompression.
- ✓ Stainless steel body and chamber.
- ✓ Damped transparent lid of highly durable polycarbonate.
- ✓ Dry-oil programme for drying the pump.
- ✓ Working hours counter for oil changes.
- ✓ Safety system with protection against vacuum failure.
- ✓ NSF-listed.



**sammic** | [www.sammic.com](http://www.sammic.com)  
**Food Service Equipment Manufacturer**

Polígono Basarte, 1. phone +34 943 15 72 36  
 20720 Azkoitia, Spain [sales@sammic.com](mailto:sales@sammic.com)



Project	Date
Item	Qty
Approved	

FOOD PRESERVATION AND SOUS-VIDE  
 VACUUM PACKING MACHINES - "SENSOR" LINE

product sheet  
 updated 10/09/2021



# VACUUM PACKING MACHINE SE-810 LL 400/50-60/3N

Floorstanding unit. 100 m<sup>3</sup>/h. 848+848 mm.



P/N 1140698

## SPECIFICATIONS

Pump capacity: 100 m<sup>3</sup>/h  
 Pump capacity (60 Hz): 120 m<sup>3</sup>/h  
 Bar length: 848 mm + 848 mm  
 Total loading: 2200 W  
 Vacuum pressure (maximum): -- mbar  
 Electrical supply: 400 V--- V / 50-60 Hz / 3N  
 ~ (9 A)

### Internal dimensions

- ✓ Width: 864 mm
- ✓ Depth: 603 mm
- ✓ Height: 215 mm

### External dimensions (WxDxH)

- ✓ Width: 960 mm
- ✓ Depth: 757 mm
- ✓ Height: 998 mm

Net weight: 250 Kg

Noise level (1m.): 75 dB(A)  
 Background noise: 32 dB(A)

### Crated dimensions

840 x 1060 x 1200 mm  
 Gross weight: 268 Kg.

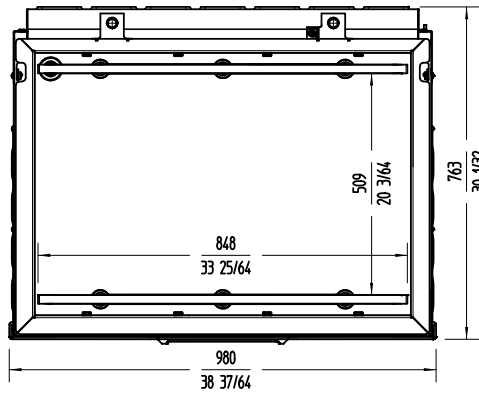
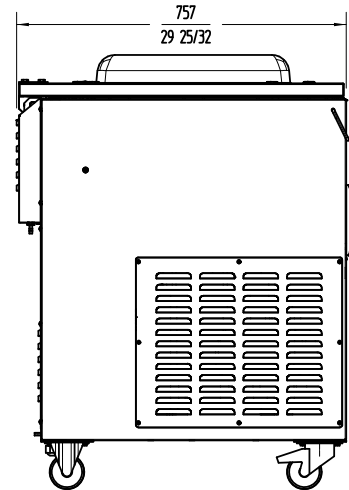
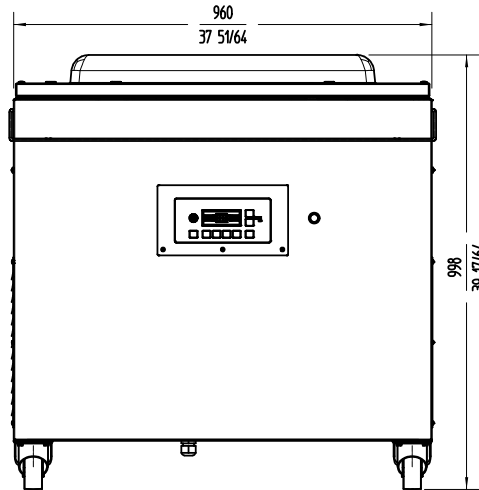

FOOD PRESERVATION AND SOUS-VIDE  
 VACUUM PACKING MACHINES - "SENSOR" LINE

**sammic** | www.sammic.com  
 Food Service Equipment Manufacturer

Polígono Basarte, 1. phone +34 943 15 72 36  
 20720 Azkoitia, Spain sales@sammic.com



Project	Date
Item	Qty
Approved	

product sheet  
 updated 10/09/2021