

## Modular Cooking Range Line EVO900 4-Electric Hot Plate Range on Electric Oven

ITEM # \_\_\_\_\_

MODEL # \_\_\_\_\_

NAME # \_\_\_\_\_

SIS # \_\_\_\_\_

AIA # \_\_\_\_\_

**392041 (Z9ECEH4QE0)**

4-hot square plates (4 kW each) electric range on electric oven (6 kW) - 400 V

**392167 (Z9ECEH4QEN)**

4-hot square plates (4 kW each) electric range on electric oven (6 kW) - 230V

### Short Form Specification

**Item No.** \_\_\_\_\_

To be installed on stainless steel feet with height adjustment up to 50 mm. Four 4 kW square cast-iron hot plates hermetically sealed to the one-piece top. Oven chamber with 3 levels of runners to accommodate 2/1 GN shelves (2 steam pans). Ribbed, cast-iron oven base plate. Exterior panels of unit in stainless steel with Scotch Brite finish. Extra strength work top in heavy duty 2 mm stainless steel. Right-angled side edges to allow flush-fitting junction between units.

### Main Features

- Unit to be mounted on stainless steel feet with height adjustment up to 50 mm. Unit can be easily mounted on cantilever systems.
- The four 4kW electric cast-iron hot plates are hermetically sealed to the one piece top and are featured with safety thermostat.
- Base compartment consists of an electric standard oven with 40 mm thick oven door for heat insulation, positioned beneath the base plate.
- Oven chamber with 3 levels of runners to accommodate 2/1 GN shelves (2 steam pans).
- Ribbed cast iron oven base plate.
- Oven to feature separate thermostats for top and bottom elements. Thermostat temperature adjustable from 110°C to 285°C.
- The special design of the control knob system guarantees against water infiltration.
- IPX5 water protection.
- Top configuration allows installation on ambient base only (not possible to install on refrigerated nor freezer base).

### Construction

- All exterior panels in Stainless Steel with Scotch Brite finishing.
- AISI 304 stainless steel worktop, 2mm thick.
- Model has right-angled side edges to allow flush fitting joints between units, eliminating gaps and possible dirt traps.
- Unit is 900mm deep to give a larger working surface area.

APPROVAL: \_\_\_\_\_



## Modular Cooking Range Line EVO900 4-Electric Hot Plate Range on Electric Oven

### Included Accessories

- 1 of GN2/1 chrome grid for static oven PNC 164250

- Rear paneling - 1000mm (EVO700/900) PNC 206375
- Rear paneling - 1200mm (EVO700/900) PNC 206376
- Chimney grid net, 400mm PNC 206400

### Optional Accessories

- GN2/1 chrome grid for static oven PNC 164250
- 2 cast iron plate bars for electric cooking top PNC 206056
- Junction sealing kit PNC 206086
- 4 wheels, 2 swivelling with brake (EVO700/900). It is mandatory to install with base supports for feet/wheels. PNC 206135
- Flanged feet kit PNC 206136
- Frontal kicking strip for concrete installation, 800 mm PNC 206148
- Frontal kicking strip for concrete installation, 1000 mm PNC 206150
- Frontal kicking strip for concrete installation, 1200 mm PNC 206151
- Frontal kicking strip for concrete installation, 1600 mm PNC 206152
- Pair of side kicking strips for concrete installation PNC 206157
- Side handrail for right/left hand PNC 206165
- Frontal handrail 800 mm PNC 206167
- Frontal kicking strip, 800 mm PNC 206176
- Frontal kicking strip, 1000 mm PNC 206177
- Frontal kicking strip, 1200 mm PNC 206178
- Frontal kicking strip, 1600 mm PNC 206179
- Pair of side kicking strips PNC 206180
- 2 panels for service duct (single installation) PNC 206181
- Large handrail (portioning shelf) 800 mm PNC 206186
- Frontal handrail 1200 mm PNC 206191
- Frontal handrail 1600 mm PNC 206192
- 2 panels for service duct (back to back installation) PNC 206202
- 4 feet for concrete installation (not for 900 line freestanding grill) PNC 206210
- Water column with swivel arm (water column extension not included) PNC 206289
- Water column extension PNC 206290
- Chimney upstand, 800 mm PNC 206304
- 2 side covering panels, height 700 mm, depth 900 mm PNC 206335
- Base support for feet or wheels - 800mm (EVO700/900) PNC 206367
- Base support for feet or wheels - 1200mm (EVO700/EVO900) PNC 206368
- Base support for feet or wheels - 1600mm (EVO700/900) PNC 206369
- Base support for feet or wheels - 2000mm (EVO700/900) PNC 206370
- Rear paneling - 800mm (EVO700/900) PNC 206374



Modular Cooking Range Line  
EVO900 4-Electric Hot Plate Range on Electric Oven

The company reserves the right to make modifications to the products without prior notice. All information correct at time of printing.

2024.01.23

**Front**

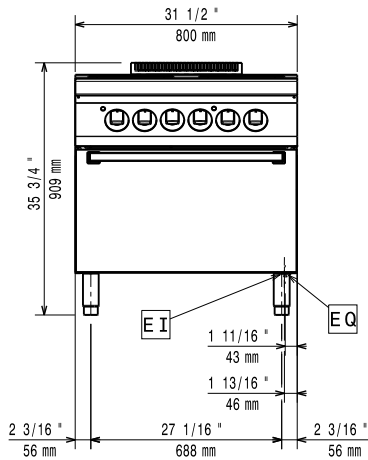

**Side**

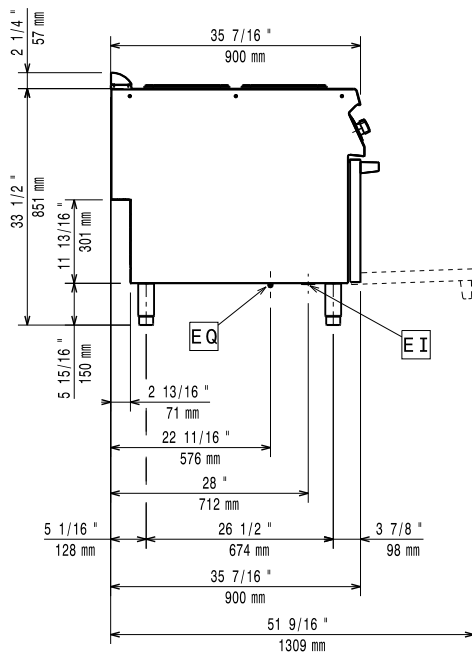

EI = Electrical inlet (power)  
EQ = Equipotential screw

**Top**

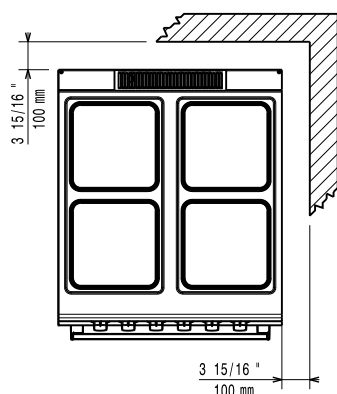

**Electric**

**Supply voltage:**

392041 (Z9ECEH4QE0) 380-400 V/3N ph/50/60 Hz  
392167 (Z9ECEH4QEN) 230 V/3 ph/50/60 Hz

**Electrical power max.:**

22 kW

**Total Watts:**

22 kW

**Predisposed for:**

380-400V 3N~ 50/60Hz 20-22kW

392041 (Z9ECEH4QE0)

**Key Information:**

**Front Plates Power:** 4 - 4 kW  
**Back Plates Power:** 4 - 4 kW  
**Front Plates dimensions:** 300x300 300x300  
**Back Plates dimensions:** 300x300 300x300  
**Oven Heat Input:** 6 kW  
**Oven working Temperature:** 110 °C MIN; 285 °C MAX  
**Oven Cavity Dimensions (width):** 575 mm  
**Oven Cavity Dimensions (height):** 300 mm  
**Oven Cavity Dimensions (depth):** 700 mm  
**External dimensions, Width:** 800 mm  
**External dimensions, Depth:** 900 mm  
**External dimensions, Height:** 850 mm

**Net weight:**

392041 (Z9ECEH4QE0) 120 kg  
392167 (Z9ECEH4QEN) 145 kg

**Shipping weight:**

392041 (Z9ECEH4QE0) 140 kg  
392167 (Z9ECEH4QEN) 139 kg

**Shipping height:**

392041 (Z9ECEH4QE0) 1080 mm  
392167 (Z9ECEH4QEN) 1120 mm

**Shipping width:**

1020 mm

**Shipping depth:**

392041 (Z9ECEH4QE0) 880 mm  
392167 (Z9ECEH4QEN) 860 mm

**Shipping volume:**

392041 (Z9ECEH4QE0) 0.97 m<sup>3</sup>  
392167 (Z9ECEH4QEN) 0.98 m<sup>3</sup>

If appliance is set up or next to or against temperature sensitive furniture or similar, a safety gap of approximately 150 mm should be maintained or some form of heat insulation fitted.

**Certification group:**

392041 (Z9ECEH4QE0) EH940  
392167 (Z9ECEH4QEN) N9CE1