

# SPECIFICATION SHEET

## MODEL: UC-S Excellence i

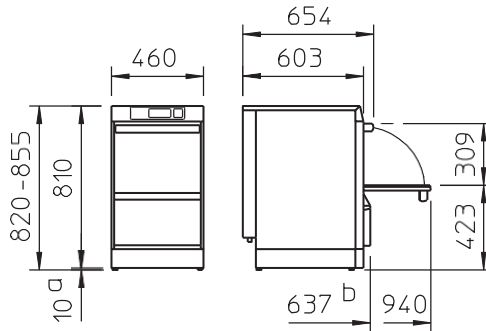

### TECHNICAL INFORMATION

Dimensions	460w x 603d x 820-855h
Rack Dimension	400 x 400 or 14x17"
Clear Entry Height	309
Rinse Water Consumption	1.8L Per Cycle

### WATER CONNECTIONS

Connection Point	3/4 inch (19mm)
Inlet Temperature	Cold - 35c Max
Flow Rate	Minimum 3 L/Min
Flow Pressure	1.4 - 6 bar

### ELECTRICAL

Single Phase (Standard)	240v 1P 50Hz - 15amp (TCL 3.4Kw)
3 Phase (optional)	415v 3P 50Hz - 15 or 20amp (TCL 7.9Kw)

### GENERAL DATA

Weight (Net/Gross)	79/88Kg
Tank Capacity	9.5L
Noise Emission	55dB(A)
Cycle Times	120/90/60 Seconds (Adjustable)

### STANDARD INCLUSIONS

1x 15amp Plug and Lead
1x 1m Flexible Water Connection Hose
1x 1m Flexible Waste Hose
1x 400 x 400, 4 Row Glass Back
1x Pre Filter Assembly, Wall Bracket & Cartridge
1x Chemical Starter Pack
1 x S/S insert to allow 14" x 17" glass racks

### STANDARD FEATURES

- Touch display with glass surface
- Vario power warewashing system for adjustable pressure
- Quadruple filtration system with clouding sensor
- Fully insulated
- Drain pump
- Rinse booster pump
- Integrated chemical dosing with storage tanks for rinse aid and detergent
- Fully integrated reverse osmosis for polish free results