



POTATO PEELER PI-10 230/50/1

10 Kg. / 22 pounds load per cycle.



P/N 1000651



DYNAMIC PREPARATION
COMMERCIAL POTATO PEELERS

SALES DESCRIPTION

Stainless steel construction commercial potato peeler. Also suitable to peel carrots and other similar products. 0-6 min. timer. Removable plate for easy cleaning.

- ✓ Construction in stainless steel.
- ✓ Lateral stirrers covered with silicon carbide abrasive (approved by NSF).
- ✓ Aluminium base plate lined with silicon carbide abrasive (approved by NSF), easily removable for cleaning purposes.
- ✓ Auto-drag of waste to the drain.
- ✓ Energy efficiency owing to engine optimisation.
- ✓ Lifiable transparent polycarbonate cover, complete with locking and safety device.
- ✓ Aluminium door with hermetic seal and safety device.
- ✓ Waterproof control board (IP65): Improved reliability against moisture and water splash.
- ✓ Water inlet system with non-return air break.
- ✓ Auxiliary contact for external electric valve.
- ✓ 0-6min timer and possibility of continuous operation.

ACCESSORIES

- Stands for potato peelers
- Filters for potato peelers



sammic | www.sammic.com
Food Service Equipment Manufacturer

Polígono Basarte, 1. phone +34 943 15 72 36
 20720 Azkoitia, Spain sales@sammic.com



Project	Date
Item	Qty
Approved	

product sheet
updated 02/07/2021



POTATO PEELER PI-10 230/50/1

10 Kg. / 22 pounds load per cycle.



P/N 1000651

SPECIFICATIONS

Hourly production: 200 Kg / 240 Kg
 Capacity per load: 10 Kg
 Timer (min-max): 0' - 6'
 Total loading : 550 W
 Electric power supply (V) : 230 V / 50 Hz / 1
 ~ / (3.5 A)
 Plug: -

External dimensions (WxDxH)

- ✓ Width: 435 mm
- ✓ Depth: 635 mm
- ✓ Height: 668 mm

External dimensions with stand

- ✓ Width with stand: 433 mm
- ✓ Depth with stand: 638 mm
- ✓ Height with stand: 1040 mm

Net weight: 36.2 Kg

Crated dimensions

670 x 470 x 810 mm
 Gross weight: 43.9 Kg.

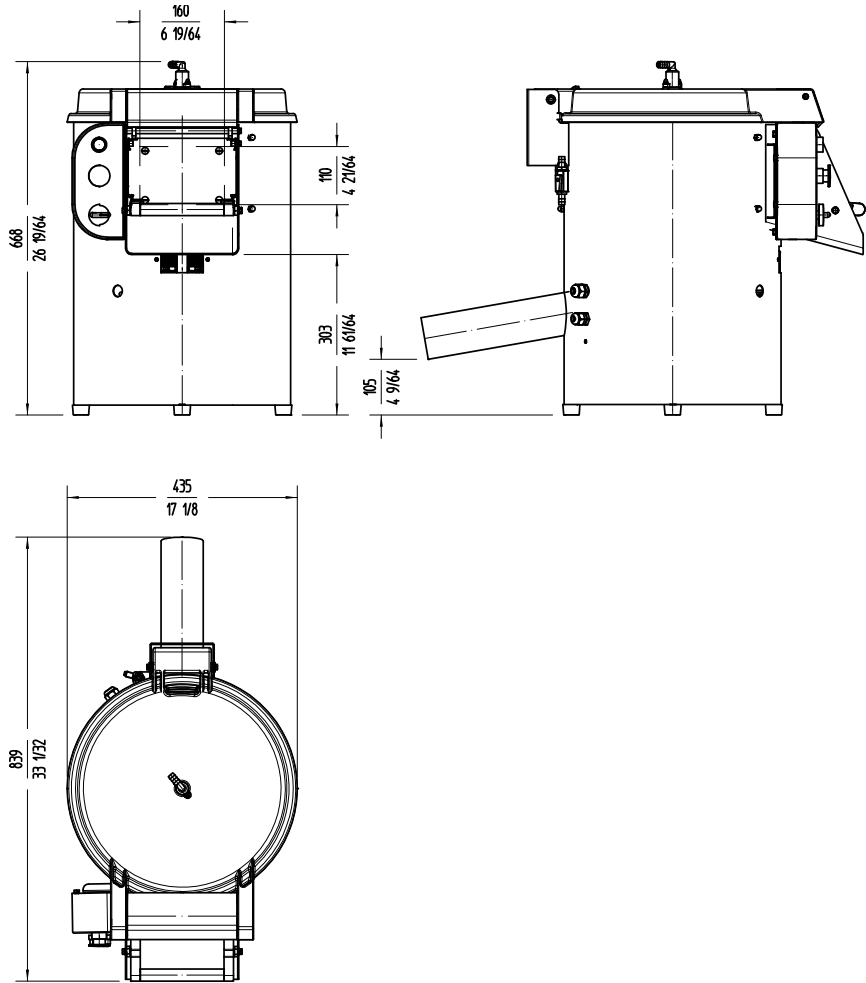

DYNAMIC PREPARATION
 COMMERCIAL POTATO PEELERS

sammic | www.sammic.com
 Food Service Equipment Manufacturer

Polígono Basarte, 1. phone +34 943 15 72 36
 20720 Azkoitia, Spain sales@sammic.com



Project	Date
Item	Qty
Approved	

product sheet
 updated 02/07/2021