



IMMERSION BLENDER XM-31 230/50-60/1 AUS

Professional immersion blender. 400 W.

P/N 3030786



FEATURES AND BENEFITS

- ✓ **All-in-one**
- ✓ Professional hand blender designed for carrying out different preparations without the need for add-on tools.
- ✓ Professional Y-blade, made from tempered steel and with a long-duration cutting edge.
- ✓ Fixed speed.
- ✓ Designed to work in recipients of up to 30 litres.
- ✓ **Maximum comfort for the user**
- ✓ Compact design: logical and manageable size.
- ✓ Ergo-design & bi-mat-grip: external casing made in two materials for an ergonomic hold. Anti-slip grip. Optimum inclination of handle, minimising fatigue.
- ✓ Click-on-arm: detachable arm with fast and secure closure.
- ✓ Hood designed to avoid splashes.
- ✓ Intuitive use: very simple operation. LED warning light in two colours to indicate the status of the machine.
- ✓ Possibility of continuous operation.
- ✓ **Built to last**
- ✓ Professional performance: capable of carrying out prolonged work without the casing overheating.
- ✓ Life-plus: equipped with a motor which has passed all of the most demanding usage tests.
- ✓ Studied geometry: casing designed to avoid rolling and falling.
- ✓ Easy to clean: detachable arm, can be cleaned under the tap.
- ✓ Approved by NSF: guaranteed safety and hygiene.
- ✓

SALES DESCRIPTION

Fixed speed motor block.

306 mm detachable arm.

Designed for continuous use in recipients of up to 30 litres.

INCLUDES

- ✓ Fixed speed motor block.
- ✓ MA-31 mixer arm.

ACCESSORIES

- Mixer arms MA-30



sammic | www.sammic.com
Food Service Equipment Manufacturer

Polígono Basarte, 1. phone +34 943 15 72 36
20720 Azkoitia, Spain sales@sammic.com



Project	Date
Item	Qty
Approved	

DYNAMIC PREPARATION
COMMERCIAL HAND BLENDERS - XM RANGE

product sheet
updated 15/07/2020



IMMERSION BLENDER XM-31 230/50-60/1 AUS

Professional immersion blender. 400 W.

P/N 3030786

SPECIFICATIONS

- Total loading: 400 W
- Maximum recipient capacity: 30 l
- Motor speed: 12000 rpm
- Blade diameter: 55 mm
- Blade guard diameter: 87.3 mm
- Electrical supply: 230 V / 50-60 Hz / 1 ~ (1.7 A)

Length

- Liquidising arm length: 306 mm
- Total length: 614 mm
- Net weight: 3.34 Kg
- Noise level (1m.): <80 dB(A)

Crated dimensions

- 455 x 475 x 117 mm
- Gross weight: 4.2 Kg.

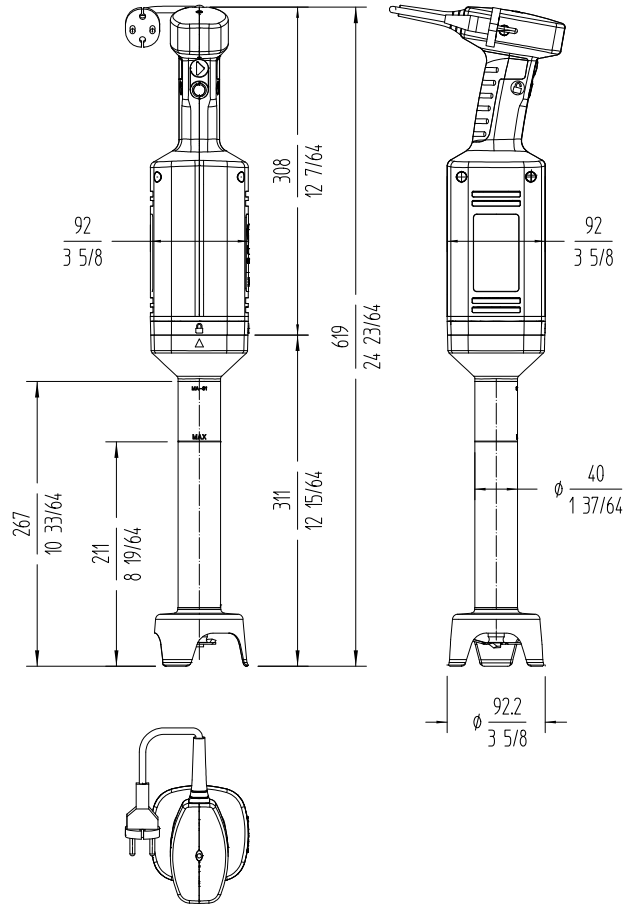

DYNAMIC PREPARATION
COMMERCIAL HAND BLENDERS - XM RANGE

sammic | www.sammic.com
Food Service Equipment Manufacturer

Polígono Basarte, 1. phone +34 943 15 72 36
20720 Azkoitia, Spain sales@sammic.com



Project	Date
Item	Qty
Approved	

product sheet
updated 15/07/2020