



# CUTLERY DRYER SAS-6001 230/50/1

Floorstanding machine with motor brake and outlet fan.



P/N 1370044

WARE WASHING  
CUTLERY DRYERS



## SALES DESCRIPTION

Output: up to 8000 pieces per hour.

- ✓ Dries, polishes and removes lime scale stains from cutlery after washing.
- ✓ Fully automatic.
- ✓ Stainless steel body and polishing tank.
- ✓ Rounded cutlery carousel, avoiding cutlery jams.
- ✓ Economy: saves on personnel costs and quick return of investment.
- ✓ Speed: hourly output of up to 8,000 pieces.
- ✓ Hygiene: the germicidal UVC-ray lamp sterilises both the cutlery and the polishing product.

## INCLUDES

- ✓ Germicidal UVC-ray lamp.
- ✓ Motor brake.
- ✓ Outlet fan.
- ✓ Drying-polishing product 5kg.

## ACCESSORIES

- Polishing product
- Front Wheel Kit



**sammic** | [www.sammic.com](http://www.sammic.com)  
Food Service Equipment Manufacturer

Polígono Basarte, 1. phone +34 943 15 72 36  
20720 Azkoitia, Spain [sales@sammic.com](mailto:sales@sammic.com)



Project	Date
Item	Qty
Approved	

product sheet  
updated 24/02/2021



# CUTLERY DRYER SAS-6001 230/50/1

Floorstanding machine with motor brake and outlet fan.



P/N 1370044

## SPECIFICATIONS

Hourly production (pieces): 5000 - 8000  
 Electrical supply: 230 V / 50 Hz / 1 ~ (5.2 A)  
 Plug: EU

### Loading

- ✓ Motor power: 300 W
- ✓ Element power: 900 W
- ✓ Uvc lamp power: 8 W
- ✓ Fan power: 50 W

### External dimensions (WxDxH)

- ✓ Width: 630 mm
- ✓ Depth: 693 (800) mm
- ✓ Height: 783 mm

Net weight: 130 Kg

### Crated dimensions

760 x 850 x 930 mm  
 Gross weight: 142 Kg.

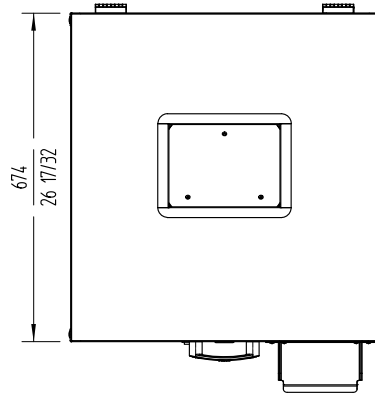
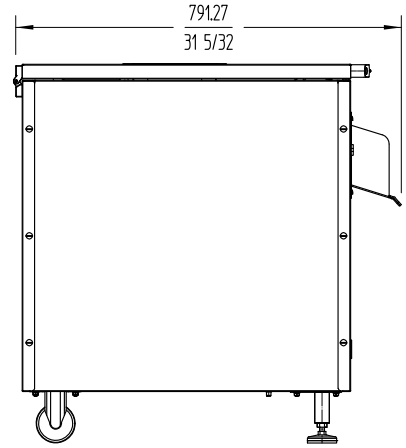
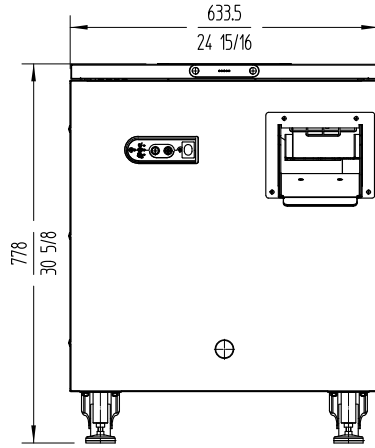

WARE WASHING  
CUTLERY DRYERS

**sammic** | www.sammic.com  
 Food Service Equipment Manufacturer

Polígono Basarte, 1. phone +34 943 15 72 36  
 20720 Azkoitia, Spain sales@sammic.com



Project	Date
Item	Qty
Approved	

product sheet  
updated 24/02/2021