



Manufactured By
ROBAND AUSTRALIA PTY LTD



OPERATING INSTRUCTIONS

REFRIGERATED FOOD BARS & BAIN MARIES

	BR Series	Version 4
Models	ERX Series	Version 5
	CRX Series	Version 4
	SRX Series	Version 3

Includes ..F.. Models (no Condenser)

Special Features:

- Carel Electronic Controller
- Refrigerated Cold Plate and Cross Fin Technology
- Quiet Operation
- Stainless Steel Construction



These instructions cover the models of ROBAND[®] Refrigerated Food Bars and Bain Maries listed above only. Although there are slight variances between models, the installation, operation, care and maintenance procedure is the same for all.

Roband® Australia is a wholly Australian owned company and has been manufacturing quality commercial catering equipment for the food service industry for more than 50 years. Roband products are engineered and manufactured to the highest standards to provide functionality, reliability and durability, and our quality products are exported world-wide.

Included in the comprehensive Roband® range are Toasters, Fryers, Milkshake Mixers, Rotisseries, Food Display Cabinets and much more.

Roband® Australia also acts as the Australian agents for Vitamix® Blenders, Noaw® Meat Slicers, Förje® Cookware, Robalec™ Soup/Rice Warmers, Robatherm Urns, Austheat® Fryers, Dipo Induction & Autofry Machines. Roband also has its own line of commercial cookware and cutlery under the Robinox® brand name.

For a complete set of brochures please contact your nearest authorised dealer or contact Roband directly at our head office.

Roband Head Office Sydney, Australia	
Roband Australia Pty Ltd 1 Inman Road Dee Why NSW 2099 AUSTRALIA	Tel: +61 2 9971 1788 Fax: +61 2 9971 1336 Email: sales@roband.com.au Web: www.roband.com.au
International Agents For additional agents please email Head Office	
Belgium Linum Europe Ph: +32 (0)56 35 92 96	Noumea: Comptoir Materiel Professionnel Ph: +687 28 50 43
Fiji: Hotel Equipment Ltd Ph: +679 672 0666	Papua New Guinea: Brian Bell & Company Pty Ltd Ph: +675 325 5411
Germany Lolsburg Ph: +49 93059878-0	Singapore: Allied Foodservice Equipment Ph: +65 62525880
GREECE K&N Engineers Ltd Ph: +30 210 520 0440	South Africa Foodservice Solutions (Pty) Ltd Ph: +31 306 017 442
Hong Kong: Chung Wah Kitchen Machine Ltd Ph: +852 2334 5411	Thailand: Seven Five Distributors Co Ltd Ph: +662 866 5858
Italy NOAW Ph: +39 0331 219723	United Kingdom Metcalfe Catering Equipment Ph: +44 (0) 1766 830456
Malaysia: Allied Food Equipment Ph: +603 9133 5833	United Arab Emirates: Boncafe Middle East LLC +9714 282 8742
Maldives: Radiant Heat Maldives Pty Ltd Ph: +960 333 4845	United Arab Emirates: Nisa Trading LLC +9714 396 6132
New Zealand: Roband New Zealand Ph: +649 274 1354	U.S.A. Smart Kitchen Solutions Ph: +1 508 244 1365

© Copyright 2015 – Roband® Australia Pty Ltd

All rights reserved. No part of this work may be reproduced or copied in any form or by any means, electronic or mechanical, including photocopying or posting to a website, without the written permission of the publisher. The material contained within this document is intended entirely for instructional purposes.

CONTENTS

INTRODUCTION	1
GENERAL PRECAUTIONS	1
PACKAGING	2
COMPLIANCE	2
MODELS WITHOUT CONDENSING UNITS	2
IMPORTANT CONSIDERATIONS BEFORE INSTALLATION	3
INSTALLATION	5
OPERATION.....	6
GENERAL SAFETY	8
SAFETY GLASS.....	8
CLEANING, CARE & MAINTENANCE	9
TROUBLESHOOTING.....	10
SPECIFICATIONS.....	11
CIRCUIT DIAGRAM.....	12
ELECTRONIC CONTROLLER- INSTRUCTIONS.....	12
Operating Parameters.....	15
Operating Parameters Continued	16
Alarm Codes	16
SPARE parts.....	17
WARRANTY	21

INTRODUCTION

Congratulations on your purchase of this quality ROBAND® product. With proper care and management your new purchase will give you years of trouble free service.

By reading these instructions carefully you can ensure that this machine is used and maintained properly, helping your new investment to perform well for you now, and to continue performing in the many years to come.

GENERAL PRECAUTIONS

This machine must only be operated by qualified person(s) who are fully versed in the operating and safety instructions described in this manual.

Service personnel should be instructed to familiarise themselves with any and all safety instructions described in this manual prior to commencement of any maintenance or service.

In the case of new personnel, training is to be provided in advance. These machines should not be operated by children or the infirm without adequate supervision.

The machine should be disconnected from all power and allowed to cool before cleaning.

Roband will accept no liability if;

- ◆ Non-authorized personnel have tampered with the machine.
- ◆ The instructions in this manual have not been followed correctly.
- ◆ Non-original spare parts are used.
- ◆ The machine is not cleaned correctly, with the right product.
- ◆ There is any damage to the unit.

PACKAGING

All care is taken when packing and Roband ensures that every unit is functional and undamaged at the time of packaging.

The package of this unit should include:

- 1) One Refrigerated Food Bar or Bain Marie (appropriate model).
- 2) This Manual.
- 3) Glass Doors, if applicable to the model purchased.

Any damage to the machine as a result of freight must be reported to the Freight Company and to the agent responsible for the dispatch of said unit within 24 hours of receipt. No claims will be accepted or entertained after this period.



RCM:

Roband® products have been designed and manufactured to comply with any and all specifications set out by the Australian Communications and Media Authority (ACMA) in regards to Electromagnetic Compatibility. As testament to such compliance these units bear the RCM symbol.

For further information contact the Australian Communications Authority, PO Box 13112, Law Courts, Melbourne VIC 8010.

MODELS WITHOUT CONDENSING UNITS

These instructions apply specifically to the refrigerated food bars and bain-marie's which are supplied complete with the refrigeration condensing unit mounted beneath the unit.

However, the information contained in these instructions is also applicable to food bars and bain-marie's which are supplied ready for connection to a condensing unit in a remote location on site. The model prefixes for these units are BF, EFX, CFX, and SFX.

Only qualified, licensed, refrigeration mechanics are to carry out the piping and commissioning of remote systems and the servicing of **all** units.

IMPORTANT CONSIDERATIONS BEFORE INSTALLATION

We want your Foodbar to work perfectly for your application so please take the time to consider these points before you install. Incorrect installation or application may create operational issues, increase service costs, or void warranty.

- ⇒ **Consider how the Foodbar is to be used.** These units are designed for the **holding and displaying** of food immediately prior to sale. They are **not** designed for **long term** storage of food. All product placed in the units should be **pre-chilled** to a temperature of 5°C or less, and should not be heaped high above the top of the pan. A refrigerator/cool room should be used for product long term storage, pre-chilling, and storage of bulk quantities not likely to be consumed quickly.
- ⇒ **Consider the temperature and humidity of the location.** These units are designed to operate in 25°C, 60% RH (Climate Class 3) ambient environment. If the ambient temperatures and/or humidity are higher than these levels the Foodbar may not be able to keep product cooled to the required temperature. Note that customers and employees will not enjoy high temperature and humidity either, so air conditioning or ventilation should be a natural consideration in any situation.
- ⇒ **Consider the location of other hot machines near the Foodbar.** Ensure that both radiant heat sources and convection heat sources from other equipment do not have a negative effect on the ventilation of the condensing unit of the Cold Foodbar.
- ⇒ **Consider how the condensing unit space will be ventilated and kept cool.** The condensing unit (the box under the Foodbar) **MUST** have good ventilation to avoid overheating and damage to the appliance.
 - The walls of any enclosing cabinet must have ventilation to the space and must be present in both the left and right sides of the cabinet, while viewed from the operator side.
 - The walls should not be closer to the condensing unit than, 15cm on the left and 30cm on the right.
 - The ventilation must promote good cross-flow air movement through the condensing unit from right to left. The openings in each side need to be as shown in the image on the following page as a minimum.
 - Do not install hot equipment inside the condensing unit space. Leave the back of the cabinet open if possible.
 - Inadequate ventilation could cause failure and will not be covered by warranty.
- ⇒ **Consider how to access the condensing unit for service and cleaning.** The condensing unit has three removable panels for service & cleaning. Access to the “control side” panel, held by screws, is required for service. Access to the “condenser coil” panel, which is easily removed by hand, is required for routine

cleaning of the condenser coil, which is very important. Failure to allow easy access **will** increase service costs. The condensing unit area should be kept clean to minimise dust and/or grease build-up on the condenser coil.

⇒ **Consider the clearance around the condensing unit during operation.** A good amount of clearance is required around the sides of the condensing unit to ensure ventilation is not obstructed during operation. At least 300mm clearance is required on the condenser coil side. At least 100mm clearance is required around each other side, and the base. Do not install or place any item within these clearances.

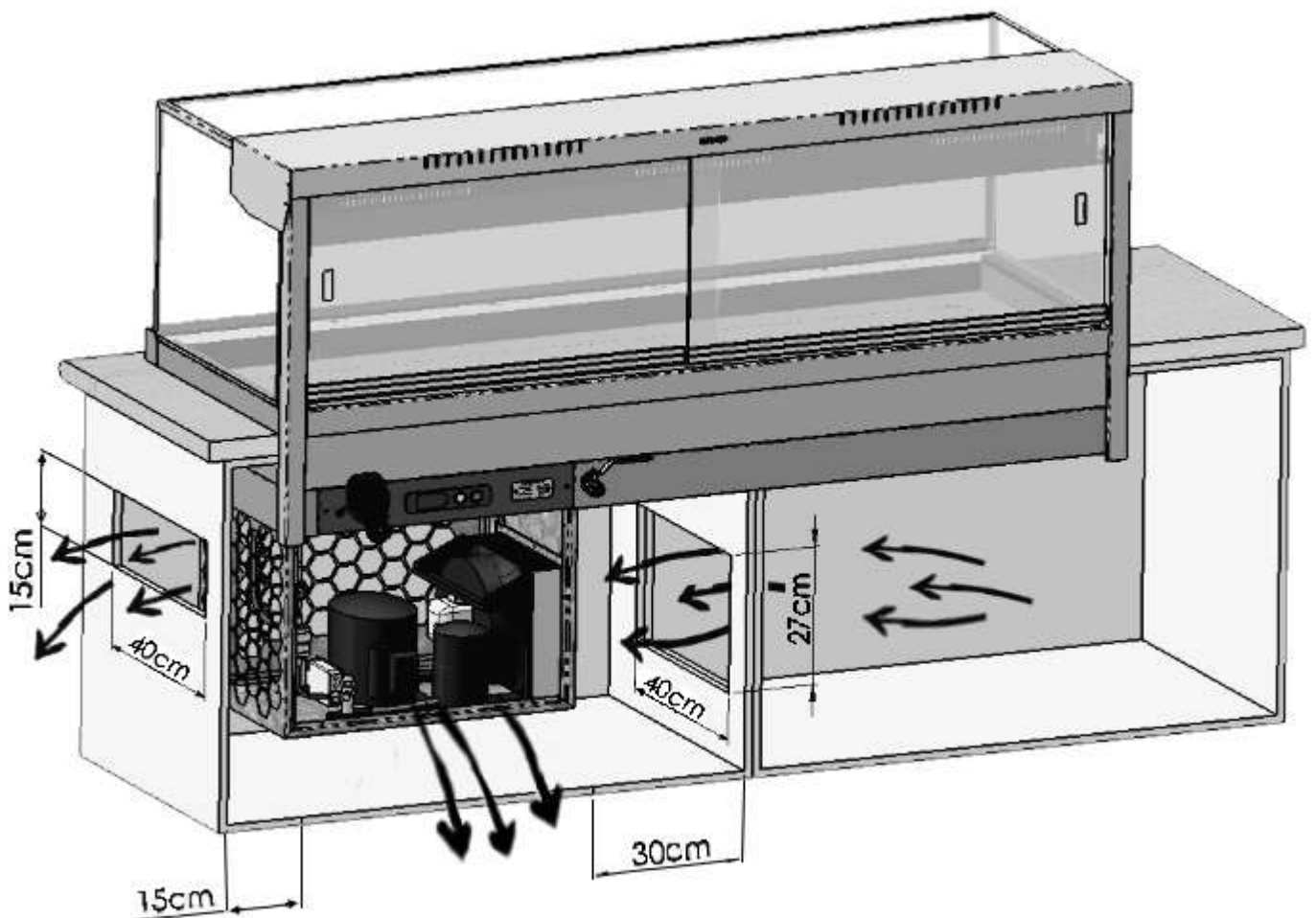

Figure 1: Ventilation Requirements

INSTALLATION

*** READ IMPORTANT CONSIDERATIONS BEFORE INSTALLATION ***

- ⇒ The unit should **not** be tipped over prior to installation as this could cause oil to run out of the compressor, leading to problems on start-up. If this has occurred, the unit should be left idle for a period of 30-60 minutes before it is run for the first time.
- ⇒ Always handle the Foodbar carefully during installation. Do not drop the Foodbar or subject it to impact or vibration, because it could crack the joins in the refrigeration pipework, or break glass.
- ⇒ Remove all the packaging materials and tape, as well as any protective plastic from the machine. Clean off any glue residue left over from the protective plastic or tape using methylated spirit.
- ⇒ The units are designed to be mounted
 - On a bench top with the condensing unit located through a hole in the bench top.
 - By being supported at each end of the Foodbar. If this latter method is utilised, the ends of the unit should be secured to prevent it from being dislodged.
 - On a trolley. Standard or Island trolleys, designed for Roband Foodbars, are available.
- ⇒ Before connecting the unit to the power supply, ensure that the light switch and the refrigeration switch is in the "OFF" position.
- ⇒ For all models plug the unit into a standard, single phase, 10 Amp power point.
- ⇒ It is highly recommended that any doors stay on these machines at all times while in use, and kept shut whenever practical. (BR units: These should be built into a suitable enclosure, typically with doors provided; otherwise product will not stay cool).
- ⇒ Once installed, the unit should be loaded with stainless steel pans, 65mm deep. The use of polycarbonate or plastic pans will insulate the food and reduce the cooling – these pans should not be used in these machines.
- ⇒ If a tray race is being fitted to with your unit use extreme caution when drilling into the legs, as described in the tray race fitting instructions, to avoid damaging either electrical wiring or refrigeration pipe work housed in the legs.

OPERATION

This information is clearly stated in Roband marketing material and should have been considered prior to purchase.

- ⇒ In cold areas the unit must be allowed to assume a temperature greater than 10°C before it is started for the first time. This will prevent lubrication problems caused by high oil viscosity in the compressor.
- ⇒ The refrigeration unit on all models is controlled by the switch with the built in green indicator light on the control panel.
- ⇒ The overhead fluorescent light is controlled by the switch with the built in white indicator light on the control panel.
- ⇒ Once started, the refrigeration unit will cycle automatically under the control of the electronic controller to maintain the space temperature at approximately 5°C. Pre-cooling the unit for approximately 45 minutes is suggested prior to placing the **pre-chilled** food in the pans.
- ⇒ The controller displays the current temperature of the space **beneath** the pans in degrees Celsius. From the factory, the set point is 2°C with a differential of 2°. This means that the cooling equipment will switch on at 4°C and off again at 2°C.
- ⇒ The set point of the controller may be altered to suit individual applications; however, these initial settings should be an adequate starting point. We recommend that the unit be used with these factory settings initially to enable you to ascertain whether or not a change is necessary. The controller will accept a minimum set point of 0°C and a maximum set point of 10°C. For details on how this is achieved, refer to the controller manufacturer's instructions on page 14 of this document. As a quick guide refer to the extract in the figure below.

Set Point



PRESS & HOLD "SET" for 1 Second
"SET POINT" Value will be displayed



PRESS ARROW "UP" or "DOWN"
to set the desired value. **



PRESS "SET" to confirm the value

During operation it is important that all pans are in place. The use of plastic pans is not recommended as they inherently insulate their contents from efficient cooling. Polycarbonate and other plastic pans are not suitable for use in these displays.

- ⇒ In Cross Fin units, the temperature of the canopy space of the food bar is determined to some degree by the amount of time that the doors are open. Care should be taken to make sure that the doors are not left open for long periods.
- ⇒ Product stored **below the top rim of the pans** will be more able to stay cool when doors are opened. We recommend product should not be piled higher than the rim of the pan for this reason.

Please note: The temperature display on the controller does **not directly** reflect the temperature of the food in the pans. To verify the food temperatures use an additional thermometer in the food directly.

IMPORTANT: These units are designed for the holding and displaying of food immediately prior to sale. They are **not** designed as a refrigerator for long term storage of food or for continuous overnight operation. All product placed in the units should be **pre-chilled** to a temperature of 5°C or less. Read IMPORTANT CONSIDERATIONS BEFORE INSTALLATION.

⚡ SAFETY ⚡

GENERAL SAFETY

⇒ This machine contains no user-serviceable parts. Roband Australia, one of our agents, or a similarly qualified person(s) should carry out any and all repairs. Any repair person(s) should be instructed to read the Safety warnings within this manual before commencing work on these units.



Steel cutting processes such as those used in the construction of this machine result in sharp edges. Whilst any such edges are removed to the best of our ability it is always wise to take care when contacting any edge.

- ⇒ Particular care should be taken to avoid contact with any steel edge, and warnings should be given in regards to the danger of such contact to any repair or maintenance person(s) prior to commencement of any servicing.
- ⇒ Only service technicians should remove any **screwed** cover panels that may be on the machine. Note the hand removable panel to clean the condensing coil is safe to remove.
- ⇒ Always ensure the power cable is not in contact with hot parts of the machine when in use, or other hot machines nearby. Ensure that any damaged power cord is replaced before further use.
- ⇒ Only qualified, licensed refrigeration mechanics are to carry out the servicing of **all** units.

SAFETY GLASS

The Toughened Safety Glass used in the ROBAND[®] Food Bars is about five times stronger than normal glass. It is designed to completely shatter into small, relatively harmless pieces in the event of breakage. These glass pieces can be collected carefully by hand without resulting in lacerations.

Note that toughened glass that has suffered a large impact or stress may not immediately break, but instead shatter randomly at some time in the future - after a few minutes, or possibly years later. It is **extremely rare** that shattering glass would ever hurt a person nearby, although pieces of shattered glass may travel several metres. It is important to check for glass pieces across a wide area and to dispose of any contaminated food product.

It is the opinion of Roband Australia that toughened glass is superior to both “Clear Float” and “Ceramic” glass with regards to function and safety. These alternatives can be very dangerous when broken, and small bits of glass could chip off and fall onto the food without being noticed.

CLEANING, CARE & MAINTENANCE

Attention to regular care and maintenance will ensure long and trouble free operation of your unit.

- ⇒ The “Control Side” doors are removable for cleaning, and allowing easier access to the tank. To remove them, lift them up, then slide them downwards and out. Handle glass carefully.
- ⇒ Cleaning of the body and tank should be carried out daily. To clean the unit use warm soapy water with a clean sponge or cloth. **Do not** use a metal scourer. It is important to turn the refrigeration unit off some time before cleaning to allow the temperature to equalise and any frost to melt.
- ⇒ Hot water should **NEVER** be poured into the tank of the unit. This could crack the evaporator coil pipe work, permanently damaging the unit.
- ⇒ When wiping out the tank, take care not to damage the probe tube located on the inside of the tank above the control panel.
- ⇒ Ensure waste water or condensate is drained from the tank at the end of each day, or more frequently if required to avoid icing.
- ⇒ The light fittings used are standard 18 Watt and 36 Watt fluorescent tubes (depending on the size of the food bar) which are obtainable from hardware and electrical stores.
- ⇒ **IMPORTANT:** The condenser coil underneath the Foodbar should be checked regularly for build-up of dirt and/or grease. The suggested frequency is every three months, or more frequently if in a dirty environment. The condenser coil can be checked and cleaned easily by removing the hand removable cover. There should be adequate access to this removable cover. Any build-up of dirt and gunge should be removed with a long bristle brush taking care not to damage the fins of the coil. Failure to clean the condenser coil regularly could lead to reduced performance or an Alarm condition.



Please note: Although every care is taken during manufacture to remove all sharp edges, care should be taken when cleaning to avoid injury.

TROUBLESHOOTING

If the Refrigerated Food Bar does not function check the following points before calling for service.

- ✓ If the green refrigeration switch light does not light up when turned on, check that the machine is plugged in correctly and that the power point is not faulty.
- ✓ If the “CHt” alarm is displayed at any time, it indicates that the condenser coil temperature is high, making it impossible for the Foodbar to work properly. A high condenser coil alarm could be caused by:
 - ⇒ Blocked condenser coil – Check that air can pass easily between the condenser coil fins. The gaps in between the fins of the condenser may need to be cleaned with a long bristle brush, to clear any gunge and dust that may have built up. Don't damage the fins by rough handling. SEE CLEANING CARE AND MAINTENANCE
 - ⇒ Poor ventilation directly near condenser coil – check that an item has not been placed next to the coil that is blocking the airflow. Read IMPORTANT CONSIDERATIONS BEFORE INSTALLATION.
 - ⇒ Poor ventilation under bench – check that the air in the condenser unit space not getting excessively hot. There needs to be good ventilation under the bench, and hot machines should not be placed near the condenser unit. Read IMPORTANT CONSIDERATIONS BEFORE INSTALLATION.
 - ⇒ Faulty condenser fan – the fan should be spinning fast and drawing air through the coil whenever the compressor is on.
- ✓ If the Foodbar is not adequately cooling the product then check the environment around the Foodbar & the condensing unit, and the way the Foodbar is being used. Read IMPORTANT CONSIDERATIONS BEFORE INSTALLATION.

Contact a Roband service representative only after these items have been checked.

SPECIFICATIONS

Model	Power Source - VAC	Power Rating - W	Width - mm	Depth - mm	Height - mm
BR22	240	480	705	615	255
BR23	240	480	1030	615	255
BR24	240	500	1355	615	255
BR25	240	500	1680	615	255
BR26	240	500	2005	615	255
ERX23	240	480	1030	615	675
ERX24	240	500	1355	615	675
ERX25	240	500	1680	615	675
ERX26	240	500	2005	615	675
CRX23	240	480	1030	615	750
CRX24	240	500	1355	615	750
CRX25	240	500	1680	615	750
CRX26	240	500	2005	615	750
SRX23	240	480	1030	615	750
SRX24	240	500	1355	615	750
SRX25	240	500	1680	615	750
SRX26	240	500	2005	615	750

Constant Research & Development may necessitate machine changes at any time.

CIRCUIT DIAGRAM

MODELS: BR SERIES UNITS, CRX SERIES UNITS, ERX SERIES UNITS & SRX SERIES UNITS

Carel PJEZ connections.

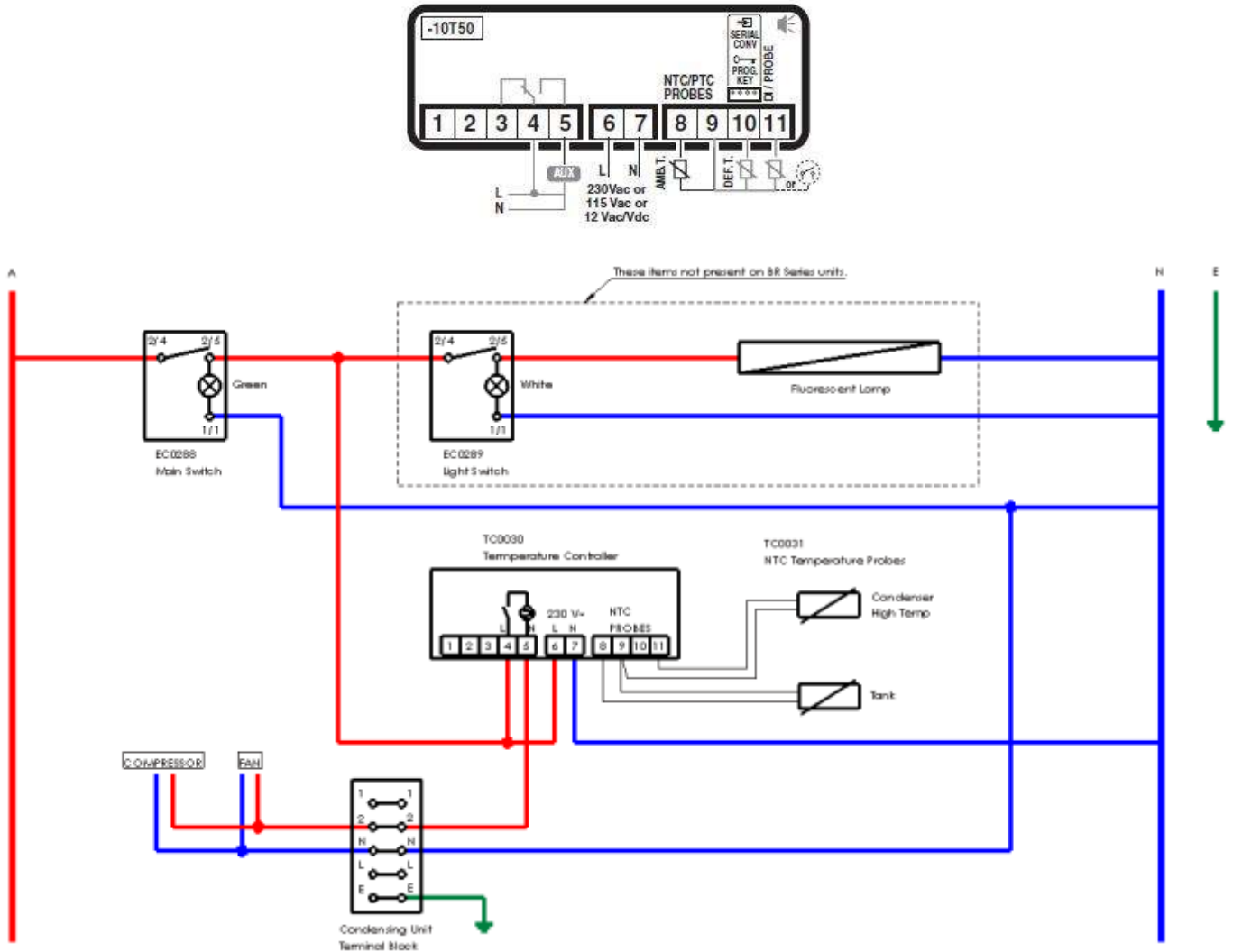

NOTE: This circuit diagram has been provided for reference and to assist qualified service and repair agents only. Under no circumstances should person's not suitably qualified attempt repairs to any electrical equipment. Please note that BR series units are not supplied with a fluorescent lamp.

ELECTRONIC CONTROLLER- INSTRUCTIONS

Dimensioni (mm) / Dimensions (mm)

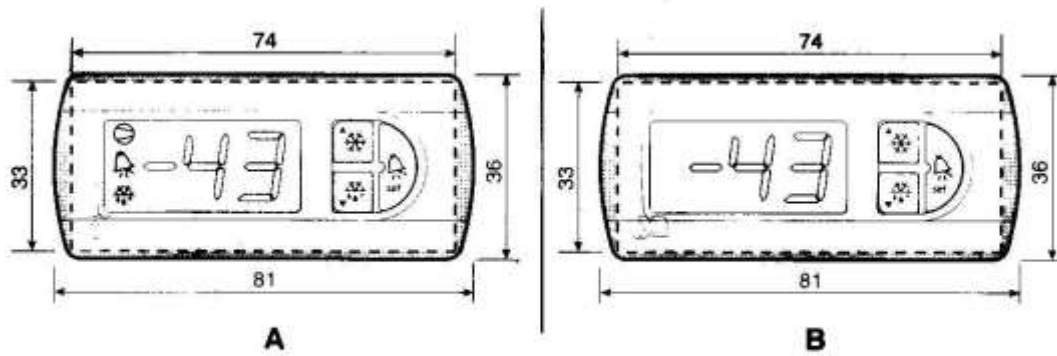

Note: Figures A and B illustrate the two versions of the instrument. The first shows the status LEDs inside the display area, while the second shows the LEDs on the backlit silicone buttons.

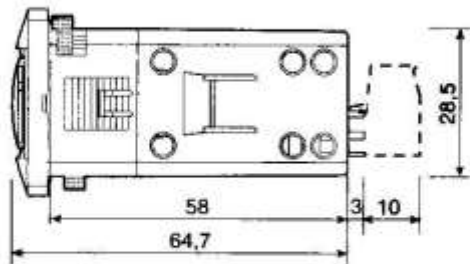

Montaggio a pannello / Panel mounting:

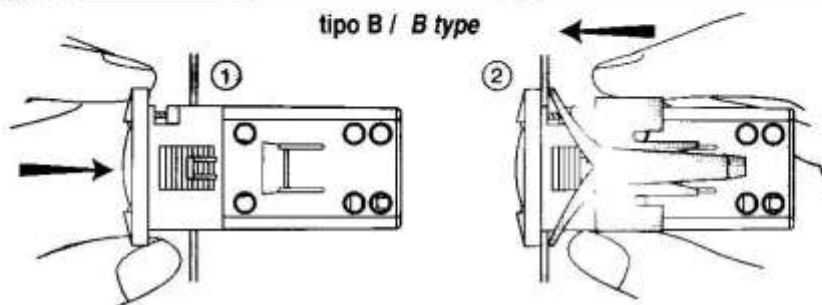
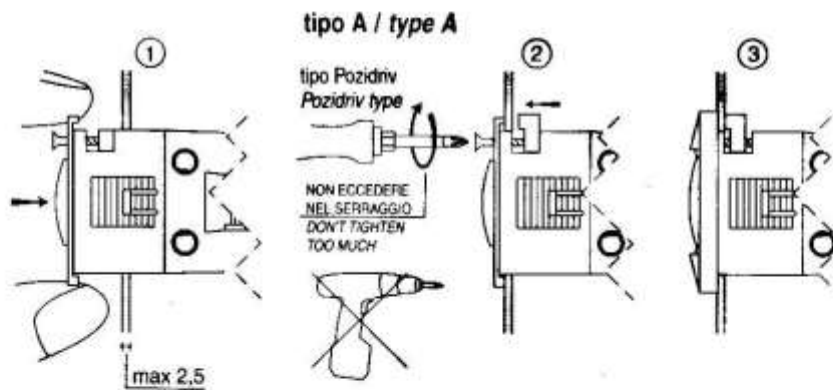



CAREL

PJEZ easy controller

Set Point



PRESS & HOLD "SET" for 1 Second
"SET POINT" Value will be displayed



PRESS ARROW "UP" or "DOWN"
to set the desired value. **



PRESS "SET" to confirm the value

All Parameters



PRESS & HOLD "SET"
for approx 5 seconds

"PS" will be displayed



PRESS "SET" then "ARROW UP" till
the password value "22" is displayed



PRESS "SET" to confirm

"PS" will be displayed



A) PRESS "ARROW UP" or "DOWN" to
select the code the of parameter to be
changed. eg rd = differential



B) PRESS "SET"
The Value Set for this parameter will be
displayed



C) PRESS "ARROW UP" or "DOWN"
to set the desired value.



D) PRESS "SET"
to confirm the value

REPEAT A-D Until all desired
parameters have been set.



PRESS & HOLD "SET" until temp is
displayed (approx 5 seconds)
to confirm all changes

Frequent (F) Parameters



PRESS & HOLD "SET" for
approx 5 seconds

"PS" will be displayed



A) PRESS "ARROW UP" or "DOWN"
to select the parameter to be changed.
eg rd = differential



B) PRESS "SET"

The Value Set for this parameter will
be displayed



C) PRESS ARROW "UP" or
"DOWN" to set the desired value.**



D) PRESS "SET"
to confirm the value

REPEAT A-D Until all desired
parameters have been set.



PRESS & HOLD "SET" until temp is
displayed (approx 5 seconds)
to confirm all changes

Please note: Please read these instruction in conjunction with the parameter list. It is recommended that the controllers be programmed before connecting or activating the plant to be controlled (eg. compressors)

** If the controller is keypad locked the value will not change. See parameter H2.

OPERATING PARAMETERS

Code	Parameter	Unit	Type	Min	Max	Default	Roband Default
/2	Probe measurement stability	-	C	1	15	4	
/4	Select display probe	-	F	1	3	1	
/5	Select °C or °F (0=°C)	-	C	0	1	0	
/6	Decimal point (0=enabled,1=disabled)	-	C	0	1	0	
/C1	Calibration of probe 1	°C/°F	F	-127	+127	0	-3
/C2	Calibration of probe 2	°C/°F	F	-127	+127	0	
/C3	Calibration of probe 3	°C/°F	F	-127	+127	0	
St	Temperature set point	°C/°F	S	r1	r2	4	2
rd	Controller differential	°C/°F	F	0	19	2	2
r1	Minimum Set Point allowed	°C/°F	C	-50	r2	-50	0
r2	Maximum Set Point allowed	°C/°F	C	r1	+150	90	10
r3	Mode 0=cool with defrost, 1=cool only, 2=heating	flag	C	0	2	0	
r4	Value to increase Set Point by from Digital Input	°C/°F	C	0	20	3	
c0	Comp. and fan start delay at power up	min	C	0	100	0	
c1	Minimum time between 2 comp starts	min	C	0	100	0	
c2	Minimum compressor OFF time	min	C	0	100	0	
c3	Minimum compressor ON time	min	C	0	100	0	
c4	Duty setting	min	C	0	100	0	
cc	Duration of continuous cycle	hours	C	0	15	4	
c6	Alarm bypass after continuous cycle	hours	C	0	15	2	
d0	Defrost type (0=elec/temp, 1=H.Gas/temp 2=elec/time,3=hot gas/time)	-	C	0	4	0	
dl	Interval between defrosts (if not using real time)	hours	F	0	199	8	16
dt	End defrost temperature, (if d0=0 or 1)	°C/°F	F	-50	127	4	
dP	Maximum defrost duration	min	F	1	199	30	30
d4	Defrost at power up (0=disabled,1=enabled)	-	C	0	1	0	
d5	Defrost delay at power up (if d4=1)	min	C	0	199	0	
d6	Display during def. (0=dF [flash],1=locked)	-	C	0	1	1	
dd	Dripping time after defrost	min	F	0	15	2	
d8	Bypass alarms after defrost	hours	F	0	15	1	
d8d	Alarm delay after door open - from dig input	hours	C	0	250	0	
d9	Defrost priority over compressor protection	-	C	0	1	0	
d/	Display defrost probe temp d/1=def P1,d/2=def P2	°C/°F	F	-	-	-	
dC	Time basis for defrost (0=hr/min, 1=min/sec)	-	C	0	1	0	
A0	Alarm and fan differential	°C/°F	C	-20	20	0	
AL	Low alarm temp (if A0=<0 absolute,if A0>0 relative)	°C/°F	F	-50	150	-50	
AH	High alarm temp (if A0=<0 absolute,if A0>0 relative)	°C/°F	F	-50	150	150	
Ad	Low and high temperature alarm delay	min	C	0	199	0	
A4	Configuration of digital input 1	-	C	0	11	0	10
A7	External alarm delay if using digital input	min	C	0	199	0	
A8	Enable alarm 'Ed' (defrost end on time)	flag	C	0	1	0	
Ac	High condensor temperature alarm set point	°C/°F	C	-50	150	70	47
AE	High condensor temperature alarm differential	°C/°F	C	0.1	20	5	1

OPERATING PARAMETERS CONTINUED

Acd	High condensor temperature alarm delay	min	C	0	250	0	15
F0	Enable evaporator fan control	flag	C	0	1	0	
F1	Evaporator fan control set point	°C/°F	F	-50	127	5	
F2	Fans cycle with comp (0=disabled,1=enabled)	flag	C	0	1	1	
F3	Fans in defrost (0=enabled,1=disabled)	flag	C	0	1	1	
Fd	Fans delay after dripping	min	F	0	15	1	
H0	Serial address	-	C	0	207	1	
H1	AUX output configuration	flag	C	0	3	0	
H2	Enable keypad (0=enabled,1=disabled)	flag	C	0	1	1	
H4	Disable buzzer (0=enabled,1=disabled)	flag	C	0	1	0	
H5	ID code (read only)	flag	F	0	31	-	
EZY	Select set of default parameters (settings below)	-	C	0	4	0	
1	normal temperature, no defrost						
2	normal temperature with timed defrost						
3	normal temperature, heated output						
4	normal temperature, defrost controlled by temp (d0=4)						

ALARM CODES

Alarm Code	Description	LED	Buzzer	Alarm	Parameters involved
E0	probe 1 error (control)	ON	ON	ON	-
E1	probe 2 error (defrost)	ON	OFF	OFF	d0=0/1/4 , F0=1
E2	probe 3 error (cond)	ON	OFF	OFF	A4=10
IA	external alarm	ON	ON	ON	A4=1 , +A7
dOR	open door alarm	ON	ON	ON	A4=7/8 , +A7
LO	low temperature alarm	ON	ON	ON	AL , Ad
HI	high temperature alarm	ON	ON	ON	AH , Ad
EE	unit parameter error	ON	OFF	OFF	-
EF	operating parameter error	ON	OFF	OFF	-
Ed	defrost ended by timeout	ON	OFF	OFF	dP , dt , d4 , A8
dF	defrost running	OFF	OFF	OFF	d6=0
cht	Condenser over temp. pre-alarm	ON	OFF	OFF	A4=10
CHt	Condenser over temp alarm	ON	ON	ON	A4=10
EtC	clock alarm	ON	OFF	OFF	If bands active

SPARE PARTS

COMMON PARTS

Models	Part Number	Description
All Models	EC0016	Switch - Rocker, amber indicating
All Models	EC0028	Terminal Block - 2 Screw, 6 Spade (QC) A & N
All Models	EC0158	Switch - Rocker, Black (30mm x 11mm)
All Models	EC0288	Switch - Rocker, On/Off Green - Suits TC0030
All Models	EC0289	Switch - Rocker, Light White - Suits TC0030
All Models	MC0087	Thermometer - minus 40 to 40°C
All Models	MC0149	Valve - Drain, 1/2" ball with lever
All Models	PC0060	Cord Clamp - 10A
All Models	RC0004	Sight Glass
All Models	RC0005	Filter Drier
All Models	RC0006	TX Valve c/w size 0 orifice - Int Eq.
All Models	TC0030	Electronic Temperature Controller - Carel
All Models	TC0031	Sensor - NTC, Carel

Size 23 Specific Parts

All Size 23RD	MS0322	Track & Rivets - 23 - Roller Doors
All CRX23 & SRX23	PS0077	Silicone - Front Glass 23
All Size 23RD	VS0085	LH Roller Door Assembly 23 c/w Frame & Glass
All Size 23RD	VS0091	RH Roller Door Assembly 23 c/w Frame & Glass

Size 24 Specific Parts

All Size 24RD	MS0323	Track & Rivets - 24 - Roller Doors
All CRX24 & SRX24	PS0078	Silicone - Front Glass 24
All Size 24RD	VS0086	LH Roller Door Assembly 24 c/w Frame & Glass
All Size 24RD	VS0092	RH Roller Door Assembly 24 c/w Frame & Glass

Size 25 Specific Parts

All Size 25RD	MS0324	Track & Rivets - 25 - Roller Doors
All CRX25 & SRX25	PS0079	Silicone - Front Glass 25
All Size 25RD	VS0087	LH Roller Door Assembly 25 c/w Frame & Glass
All Size 25RD	VS0093	RH Roller Door Assembly 25 c/w Frame & Glass

Size 26 Specific Parts

All Size 26RD	MS0325	Track & Rivets - 26 - Roller Doors
All CRX26 & SRX26	PS0080	Silicone - Front Glass 26
All Size 26RD	VS0088	LH Roller Door Assembly 26 c/w Frame & Glass
All Size 26RD	VS0094	RH Roller Door Assembly 26 c/w Frame & Glass

BR Specific Parts

Models	Part Number	Description
All BR	MS0064	Drain Pipe Assembly - 1/2 " Ball Valve, ERX Series

CRX Specific Parts		
Models	Part Number	Description
CRX23	GC0029	Glass - Front, Toughened
CRX24	GC0030	Glass - Front, Toughened
CRX25	GC0031	Glass - Front, Toughened
CRX26	GC0032	Glass - Front, Toughened
All CRX	GC0049	Glass - Side, 38mm leg (post March 99)
All CRX	MS0062	Drain Pipe Assembly - 1/2 " Ball Valve, CRX Series
All CRX	PS0075	Silicone - Side Glass
All CRX	PS0081	Silicone - Top
All CRX	PS0109	Silicone - Vertical on Front Glass

ERX Specific Parts		
Models	Part Number	Description
ERX22	GC0011	Glass - Front
ERX23	GC0012	Glass - Front
ERX24	GC0013	Glass - Front
ERX25	GC0014	Glass - Front
ERX26	GC0015	Glass - Front
All ERX	GC0017	Glass - Side
All ERX	MS0064	Drain Pipe Assembly - 1/2 " Ball Valve, ERX Series

SRX Specific Parts		
Models	Part Number	Description
All SRX	GC0102	S Series Foodbar Side Glass - 5mm Toughened
SR22	GC0103	Top Glass - 8mm Toughened
SR23	GC0104	Top Glass - 8mm Toughened
SR24	GC0105	Top Glass - 8mm Toughened
SR25	GC0106	Top Glass - 8mm Toughened
SR26	GC0107	Top Glass - 8mm Toughened
SR22	GC0108	Front Glass - 6mm Toughened
SR23	GC0109	Front Glass - 6mm Toughened
SR24	GC0110	Front Glass - 6mm Toughened
SR25	GC0111	Front Glass - 6mm Toughened
SR26	GC0112	Front Glass - 6mm Toughened
All SRX	MS0062	Drain Pipe Assembly - 1/2 " Ball Valve, CRX Series
All SRX	PS0075	Silicone - Side Glass
All SRX	PS0081	Silicone - Top

Condensing Units - Complete		
Models	Part Number	Description
BR22-24	RC0001	Condensing Unit Complete
BR25-26	RC0002	Condensing Unit Complete
CRX23	RC0002	Condensing Unit Complete
CRX24	RC0029	Condensing Unit Complete
CRX25-26	RC0032	Condensing Unit Complete
ERX23	RC0002	Condensing Unit Complete
ERX24	RC0029	Condensing Unit Complete
ERX25-26	RC0032	Condensing Unit Complete
SRX23	RC0002	Condensing Unit Complete
SRX24	RC0029	Condensing Unit Complete
SRX25-26	RC0032	Condensing Unit Complete

NOTES

(Record any preferred times or settings etc. here to act as a quick reference for other users)

WARRANTY

Every care is taken to ensure that no defective equipment leaves our factory and all goods manufactured by us are guaranteed against defective workmanship and materials for a period of 12 months from the date of purchase. Roband Australia's obligations pursuant to this express warranty being limited to the repair or replacement of the defective goods or materials, at its option and subject to the terms contained within this Warranty statement. Where relevant, glass, Teflon® and lamps are **not** included in this warranty and RCD tripping due to moisture absorption by Tubular Heating Elements is not considered a warranty fault.

Generally, all goods claimed under this warranty must be returned to the factory or an authorized service agent, freight prepaid, for inspection. All parts deemed to be defective will be replaced, however, no claims will be entertained for second hand products, or parts damaged in transport, misused or modified in any way without our approval. For machines that are not considered to be portable (e.g. food bars, rotisseries, large hotplates and some bain maries), on site warranty service will be provided in capital city metropolitan areas only. In all other locations, the customer is responsible for all travelling time/service call costs and payment for this will be required prior to the commencement of the repair. The labour costs to actually repair the fault will be met by the company.

Any repairs or replacement of defective goods or materials pursuant to this warranty, must be authorized by Roband Australia prior to any action being taken. The company reserves the right to reject a claim for warranty if it is not completely satisfied with the circumstances under which it occurred and any other costs incurred for false claims or faults due to incorrect usage etc. are the responsibility of the claimant. Roband Australia Pty Ltd nor any subsidiary company or Agent shall be liable for loss of profit or damage to other equipment and property except where it is in breach of the guarantees provided in accordance with Schedule 2 of the Competition and Consumer Act 2010 (Cth) or the applicable legislation from time to time.

The goods come with guarantees that cannot be excluded under the Australian Consumer Law (ACL). You are entitled to a replacement or refund for a major failure and for compensation for any other reasonably foreseeable loss or damage. You are also entitled to have the goods repaired or replaced if they fail to be of acceptable quality and the failure does not constitute a major failure.

Generally, authorized service agents are located in all areas which have authorized distribution dealers. For the name of your nearest Australian authorised service agent, please contact:

Roband Australia Pty Ltd

1 Inman Road, Cromer, NSW 2099

Warranty Number: 1800 268 848

Phone: (02) 9971 1788 Fax: (02) 9971 1336

All other countries please contact your selling Agent.

Please complete the following details and keep this card in a safe place.

NAME _____

ADDRESS _____

MODEL No: _____ SERIAL No: _____ DATE PURCHASE _____

NAME OF DEALER: _____

PLEASE RETAIN THIS SECTION FOR YOUR RECORDS

DO NOT POST

ROBAND® AUSTRALIA PTY LTD