

TOP VIEW

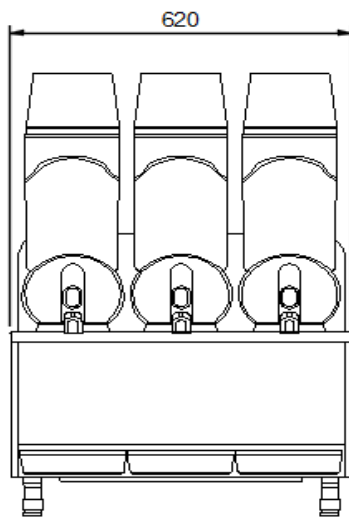

FRONT VIEW
NTS

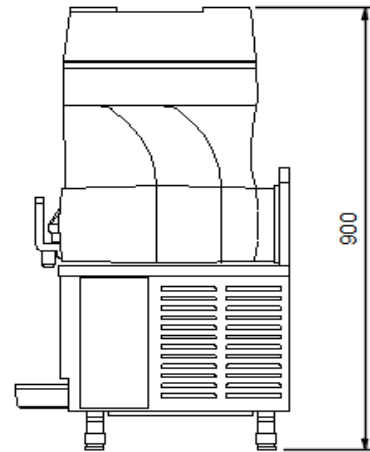

SIDE VIEW



GRANITIME 1



GRANITIME 2



GRANITIME 3

The **GBG Granitime** machines have European design and built, fast to freeze, simple to operate and built to last. A highly versatile machine designed to make and serve slush, sherbet and frozen cocktails.

STANDARD FEATURES

- Enlarged refrigeration capacity.
- Highest level of performance in the most challenging environments.
- New push and pull taps preventing product pour issues.
- Thorough and continuous product mixing.
- 12lt per bowl capacity.
- Brushed stainless steel body .
- Simple operation.
- Built strong yet simple to clean.

SPECIFICATION					
CODE	W x D x Hmm	KG	POWER REQ.	WATTS	CAPACITY
GRANITIME 1	210 x 500 x 900	30	10amp	800	1 x 12ltr bowl
GRANITIME 2.	420 x 500 x 900	55	10amp	1000	2 x 12ltr bowl
GRANITIME 3	620 x 500 x 900	70	10amp	1200	3 x 12ltr bowl